

SCALE 1 : 3

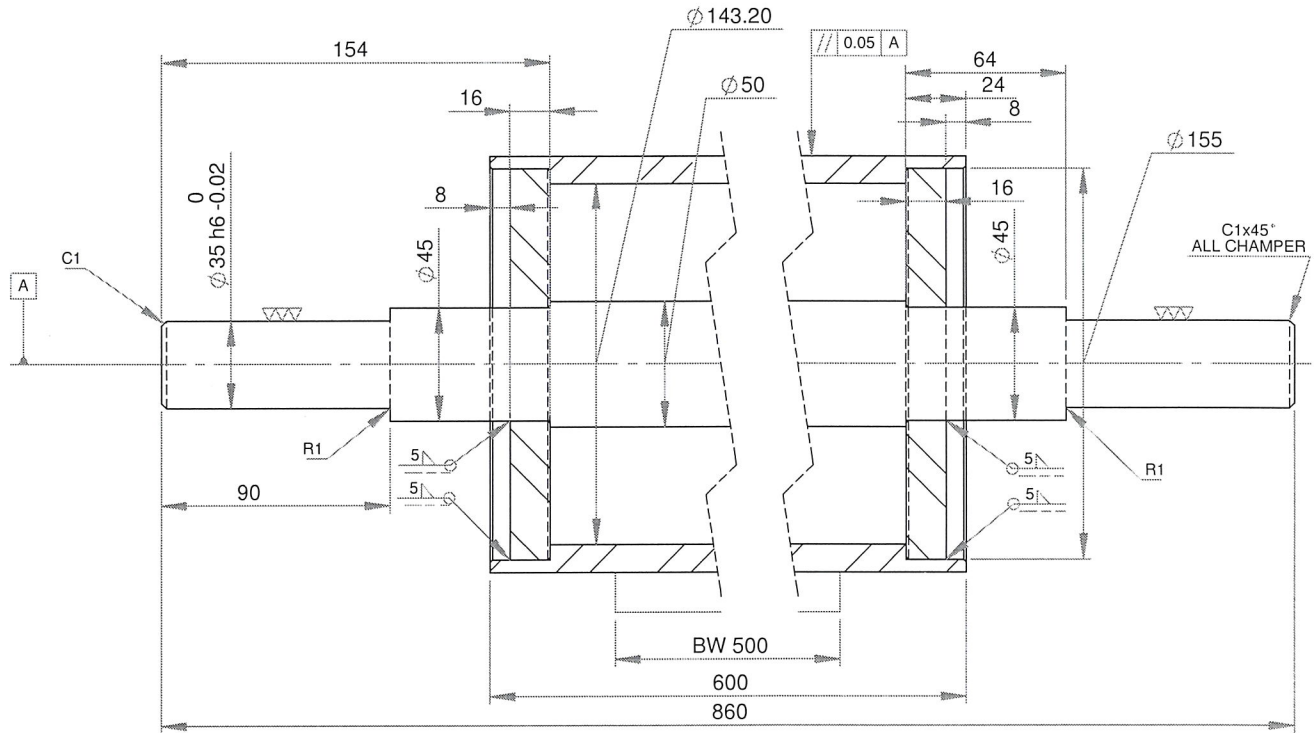

SECTION A-A
SCALE 1 : 3

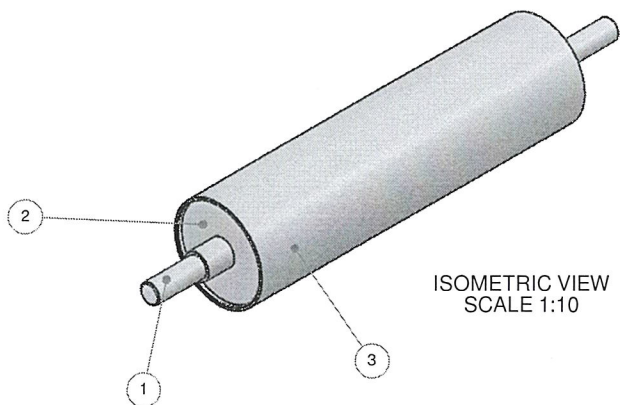

ISOMETRIC VIEW
SCALE 1:10

** INCOMING PART WILL BE CHECK. IT WILL RETURN IF NOT PASS **

POLISHING	GRINDING	NORMAL MACHINING (SMOOTH SURFACE)	NORMAL MACHINING (ROUGH SURFACE)
▽▽▽	▽▽	▽	▽

3	SHAFT	1	S45C	-
2	HOLDER SHAFT	2	SS400	-
1	BODY	1	STEEL PIPE 6" SCH 80	-
POS	DESCRIPTION	QTY	MATERIAL	REMARKS
FILE DIR: \\192.168.4.15\mechanical\Draft Nuryana\Proyek Pak Dadang\BC\Snub pulley\BW 500\BC-02\		SCALE: 1:10		ASSY NO.
DIM: mm		NAME		DATE
DRAWN		ENDEN		15-Nov-18
DESIGN		ADI P		15-Nov-18
CHECK		YESSIKO		
APRV		M.NUGRAHA		
()= GENERAL TOLERANSI ±0.2% x DIMENSION				
REF DWG NO.				
MECHANICAL ENGINEERING SECTION				
TITLE RAW MATERIAL - BELT CONVEYOR 02 (BW500)				
SNUB PULLEY				

