

SECTION B-B

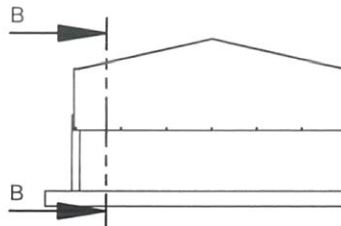

DETAIL I
SCALE 1 : 50

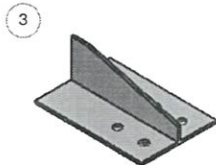

SCALE 1 : 10

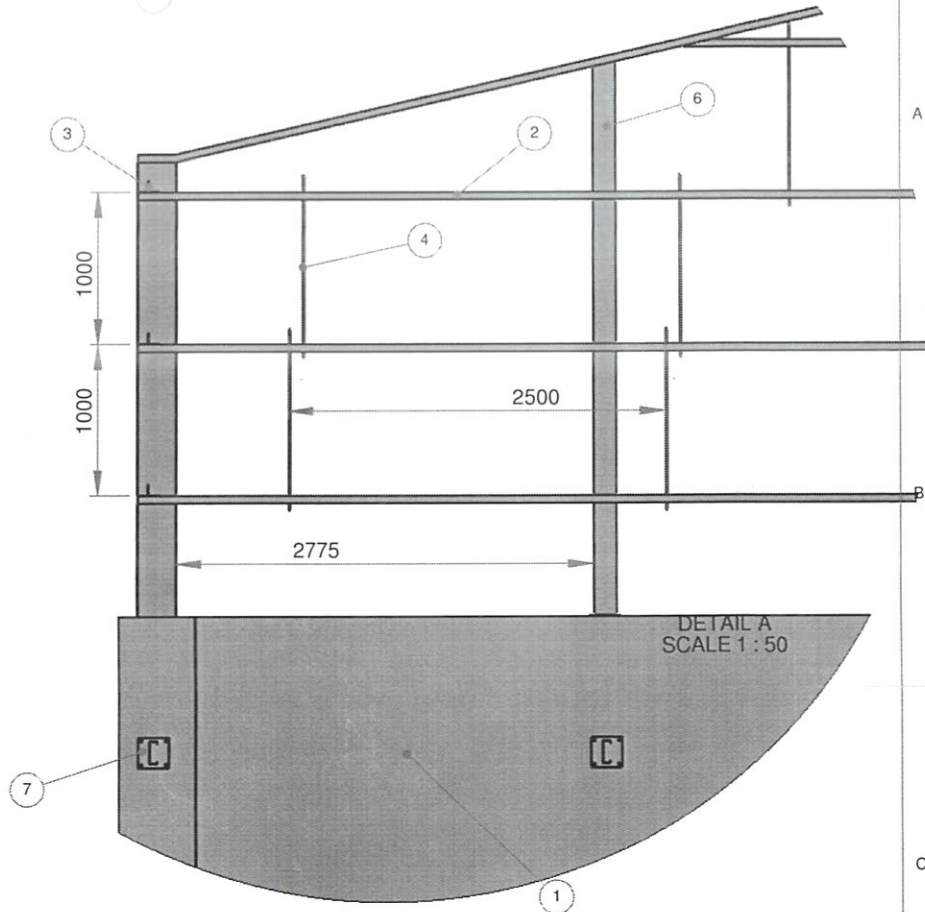
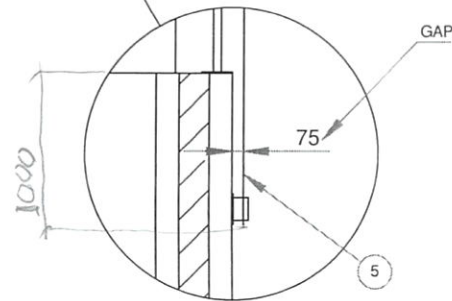

DETAIL A
SCALE 1 : 50

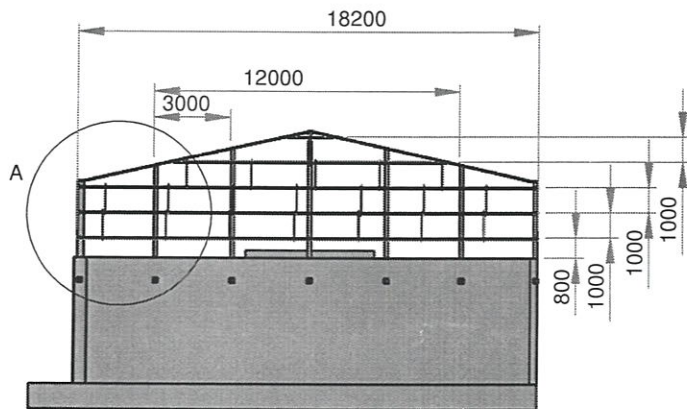

SCALE 1 : 300

** INCOMING PART WILL BE CHECK. IT WILL RETURN IF NOT PASS **

6	SUPPORT CNP	5	CNP+MILD STEEL PLATE 8mm	-
5	CLADING	1	ZINCALUME	-
4	SUPPORT STRAIGHT CNP	1	1	-
3	HOLDER CNP	6	MILD STEEL PLATE 5mm	-
2	CNP	1	150X50X20X3.2	-
1	BAY	1	-	-

POS	DESCRIPTION	QTY	MATERIAL	REMARKS
-----	-------------	-----	----------	---------

FILE DIR:
\\192.168.4.15\mechanical\Draft Nuryana\Proyek Pak Nugiel\Cover Bay\

DIM: mm	NAME	DATE
DRAWN	ENDEN	9/20/2017
DESIGN	ENDEN	
CHECK	YESSIKO	
APRV	RULLY	
CANCEL DWG NO.		
REF DWG NO.		

SCALE: 1:500	DIM: mm	ASSY NO.
MECHANICAL ENGINEERING SECTION		

TITLE
CLADING BAY

POLISHING	GRINDING	NORMAL MACHINING (SMOOTH SURFACE)	NORMAL MACHINING (ROUGH SURFACE)
▽▽▽	▽▽	▽	▽
1		2	3