

SCALE 1 : 6

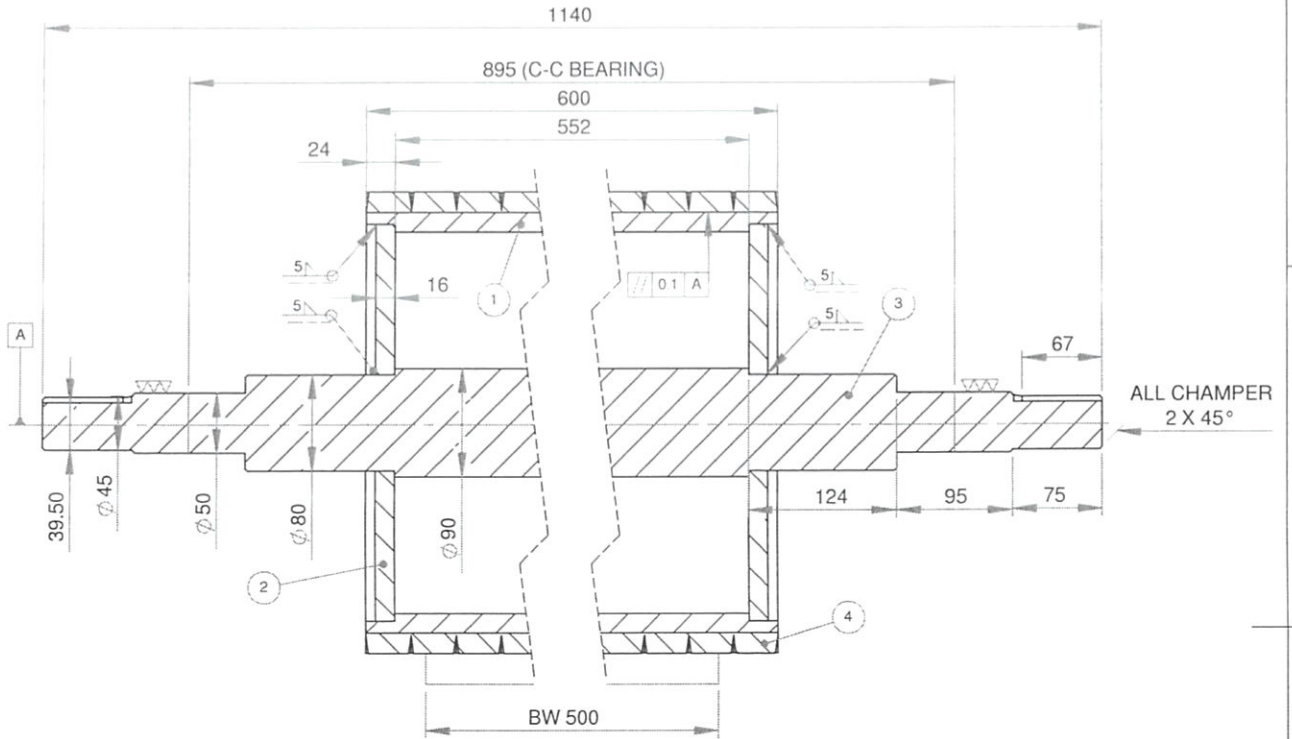

SECTION A-A
SCALE 1 : 6

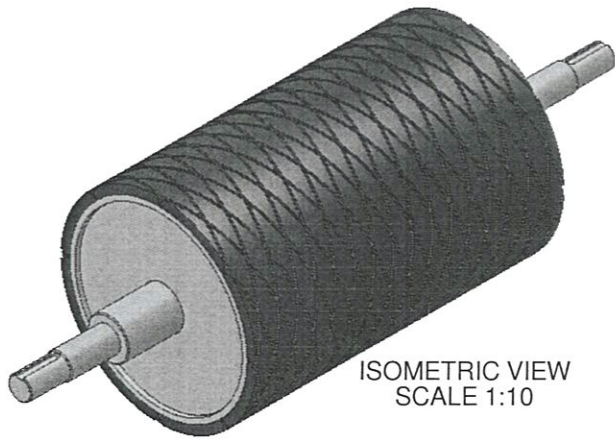

ISOMETRIC VIEW
SCALE 1:10

** INCOMING PART WILL BE CHECK. IT WILL RETURN IF NOT PASS **

POLISHING	GRINDING	NORMAL MACHINING (SMOOTH SURFACE)	NORMAL MACHINING (ROUGH SURFACE)
▽▽▽	▽▽	▽	▽

4	RUBBER LAGGING	1	HERRINGBONE TYPE 55-65 SHORE A	MAKE A FLOW 1:5mm
3	SHAFT	1	S45C	SOLID MATERIAL
2	HOLDER PLATE	2	SS400	SOLID MATERIAL
1	STEEL PIPE 14" SCH80	1	STEEL PIPE 14" SCH80	PIPE
POS	DESCRIPTION	QTY	MATERIAL	REMARKS
FILE NO. 4.15mechanical\Draft Nuryana\Proyek Pak Dadang\Head pulley\Head pulley BC-02\Revisi-1\		SCALE: 1:10		ASSY NO.
DIM: mm		NAME		DATE
DRAWN		ENDEN		12/7/2017
DESIGN		AVAILABLE		
CHECK		YESSIKO		
APRV		RULLY		
CANCEL DWG NO.				
REF DWG NO.				
MECHANICAL ENGINEERING SECTION				
TITLE BELT CONVEYOR				
HEAD PULLEY				



PT SCG LIGHTWEIGHT CONCRETE INDONESIA

A4

2012-DWG-RMA-BC02-M-010A

REV NO. PAGE

1