

SCALE 1 : 1

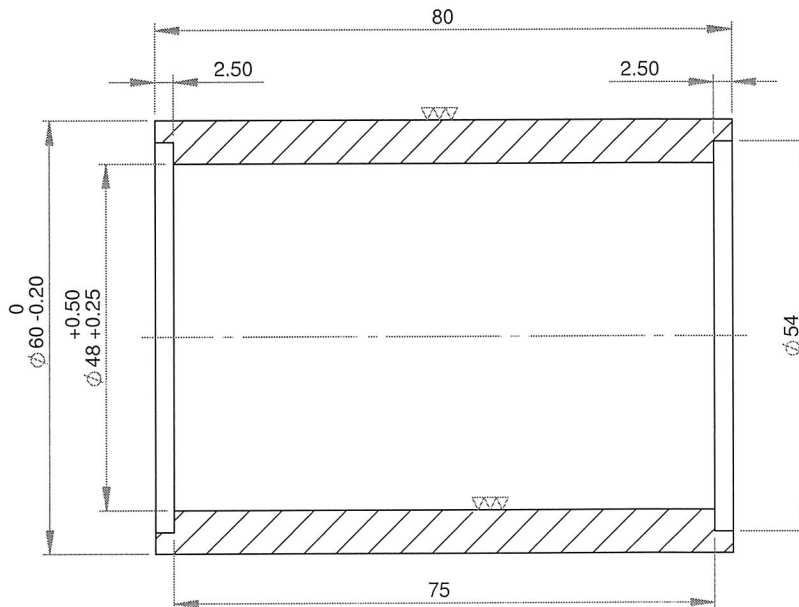

SECTION A-A
SCALE 1 : 1



ISOMETRIC VIEW
SCALE 1 : 2

** INCOMING PART WILL BE CHECK. IT WILL RETURN IF NOT PASS **

POLISHING	GRINDING	NORMAL MACHINING (SMOOTH SURFACE)	NORMAL MACHINING (ROUGH SURFACE)
▽▽▽	▽▽	▽	▽

1	BACK SHAFT SLEEVE	1	VCN150	52-57 HRC
POS	DESCRIPTION	QTY	MATERIAL	REMARKS
FILE DIR: \\192.168.4.15\mechanical\Draft Nuryana\Proyek Pak Yessiko\Pump MST\4-3\		SCALE: 1:20		ASSY NO.
MECHANICAL ENGINEERING SECTION				
TITLE MIXING PLAN - SLURRY PUMP MST 4/3		BACK SHAFT SLEEVE		
DRAWN ENDEN 01-Oct-18		REFF DWG NO.		
DESIGN YESSIKO 1-10-18		PT SCG LIGHTWEIGHT CONCRETE INDONESIA		
CHECK CHOLIDIN 2-10-18		A4 2012-DWG-MPL-MS43-M-001-3		
APRV M.NUGRAHA 2-10-18		REV NO. 2		
() = GENERAL TOLERANSI ±0.2% x DIMENSION		PAGE 4		