

SCALE 1 : 1

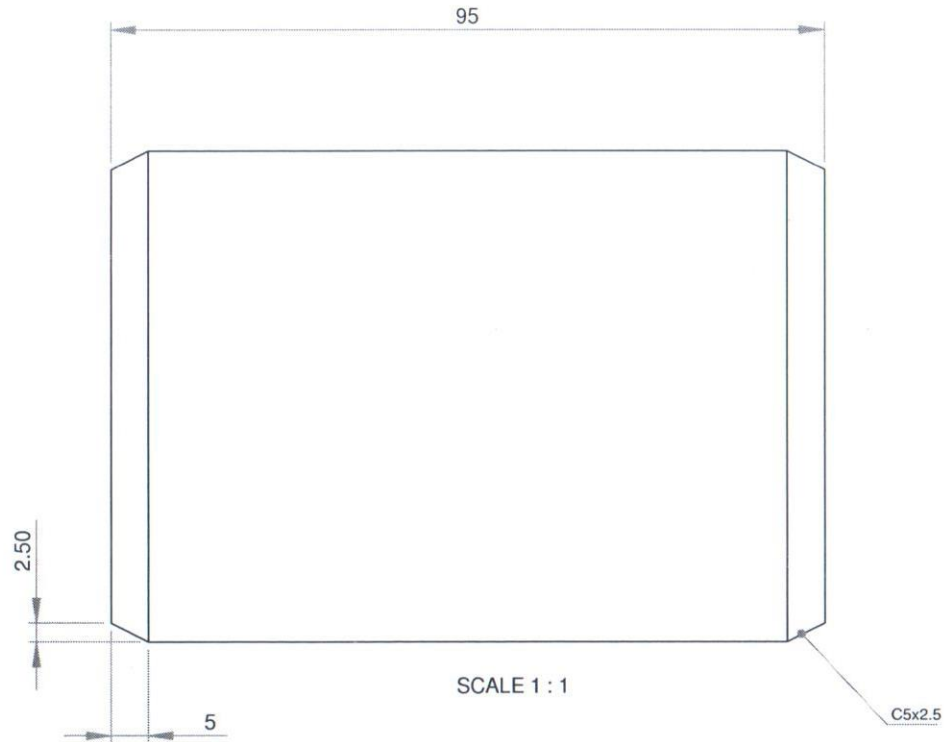

SCALE 1 : 1

** INCOMING PART WILL BE CHECK. IT WILL RETURN IF NOT PASS **

POLISHING	GRINDING	NORMAL MACHINING (SMOOTH SURFACE)	NORMAL MACHINING (ROUGH SURFACE)

1	NYLON COUPLER	1	NYLON	
POS	DESCRIPTION	QTY	MATERIAL	REMARKS
FILED	4.15\mechanical\Draft Nuryana\Proyek mas gama\Teflon Coupler			
DIM: mm	NAME	DATE	SCALE: 1:1	DIM: mm ASSY NO.
DRAWN	ENDEN	6/14/2017		
DESIGN	ENDEN			
CHECK	GAMA			
APRV	RULLY			
CANCEL DWG NO.				
REF DWG NO.				
MECHANICAL ENGINEERING SECTION				
NYLON COUPLER				
	PT SCG LIGHTWEIGHT CONCRETE INDONESIA	A4	2012-DWG-RMA-BM03-051	REV NO. PAGE
				2