

1 2 3 4 5 6

A

B

C

D

A

B

C

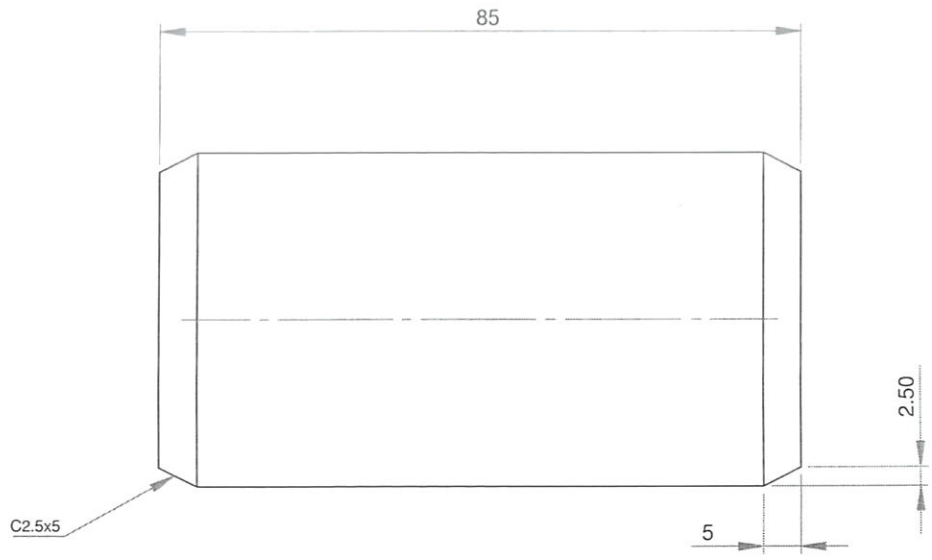
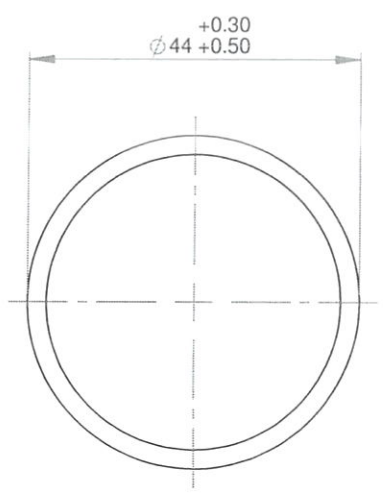

** INCOMING PART WILL BE CHECK. IT WILL RETURN IF NOT PASS **

POLISHING	GRINDING	NORMAL MACHINING (SMOOTH SURFACE)	NORMAL MACHINING (ROUGH SURFACE)
1			2

1	TEFLON COUPLER	1	NYLON	
POS	DESCRIPTION	QTY	MATERIAL	REMARKS
FILE DIR: \\192.168.4.15\mechanical\Draft Nuryana\Proyek mas gama\Teflon Coupler			SCALE: 1:1	DIM: mm ASSY NO.
MECHANICAL ENGINEERING SECTION				
DIM: mm	NAME	DATE	TITLE	
DRAWN	ENDEN	10/13/2017	GEARBOX TO BAL LMILL	
DESIGN	AVAILABLE		<h2 style="text-align: center;">NYLON COUPLER</h2>	
CHECK	YESSIKO	13/16/17		
APRV	RULLY			
CANCEL DWG NO.				
REF DWG NO.				
PT-SCG LIGHTWEIGHT CONCRETE INDONESIA			A4 2012-DWG-RMA-BM03-050	
				REV NO. PAGE
				1 1

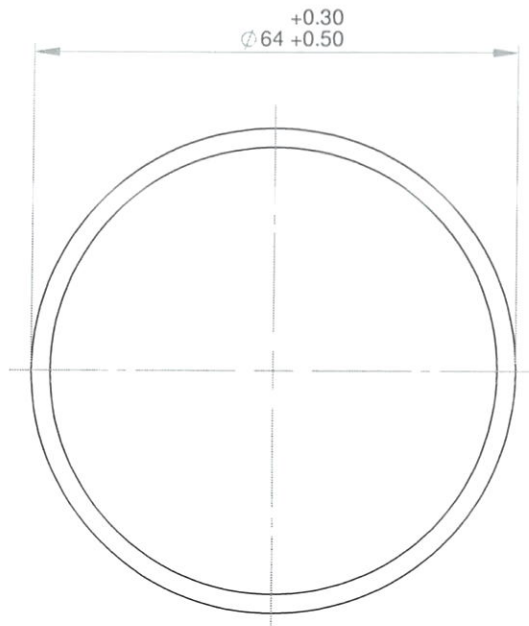

SCALE 1 : 1

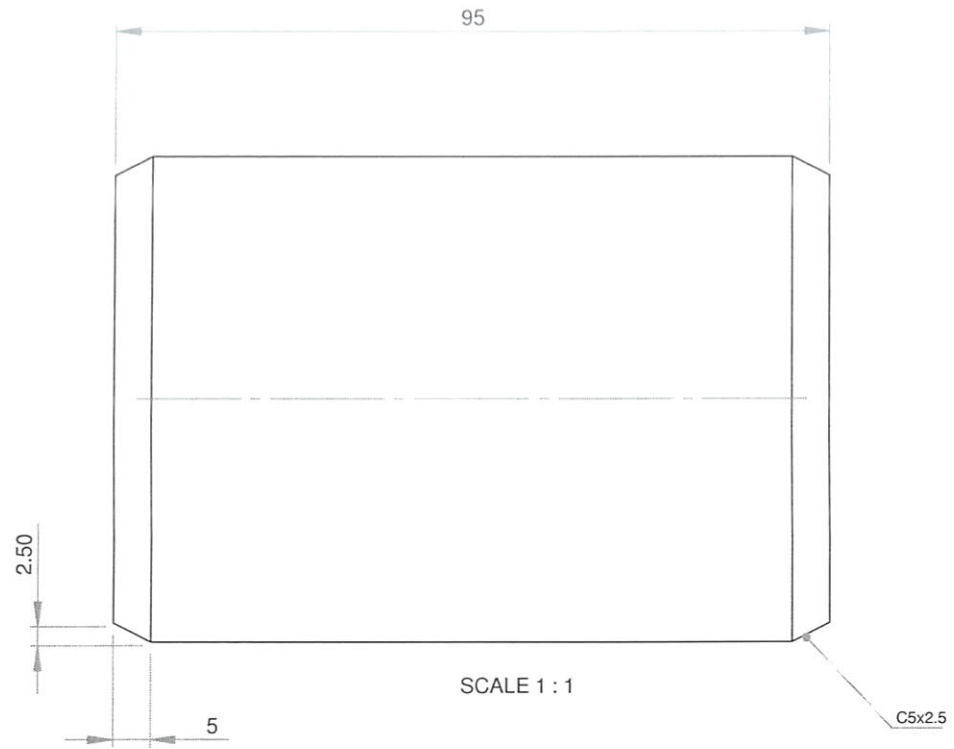

SCALE 1 : 1

** INCOMING PART WILL BE CHECK. IT WILL RETURN IF NOT PASS **

POLISHING	GRINDING	NORMAL MACHINING (SMOOTH SURFACE)	NORMAL MACHINING (ROUGH SURFACE)
▽▽▽	▽▽	▽	▽

1	NYLON COUPLER	1	NYLON	
POS	DESCRIPTION	QTY	MATERIAL	REMARKS
FILE D:\B.4.15\mechanical\Draft Nuryana\Proyek mas gama\Teflon Coupler\			SCALE: 1:1	DIM: mm ASSY NO.
MECHANICAL ENGINEERING SECTION				
DIM: mm	NAME	DATE	TITLE	
DRAWN	ENDEN	10/13/2017	GEARBOX TO BAL LMILL	
DESIGN	AVAILABLE			
CHECK	YESSIKO			
APRV	RULLY			
CANCEL DWG NO.				
REF DWG NO.				
PT SCG LIGHTWEIGHT CONCRETE INDONESIA			A4	2012-DWG-RMA-BM03-051
				REV NO. PAGE
				1 2