

ISOMETRIC VIEW  
SCALE 1:2  
MASS: 2.2 KG

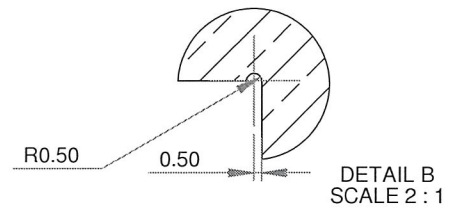
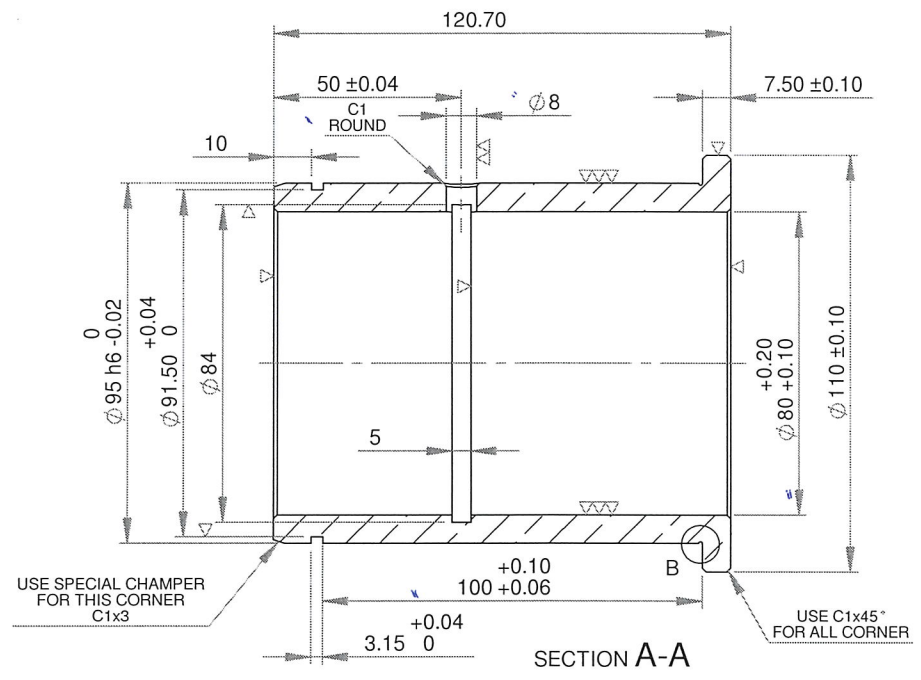

\*\* INCOMING PART WILL BE CHECK. IT WILL RETURN IF NOT PASS \*\*

POLISHING	GRINDING	NORMAL MACHINING (SMOOTH SURFACE)	NORMAL MACHINING (ROUGH SURFACE)
▽▽▽	▽▽	▽	▽

1	BUSHING	1	BRONZE	
POS	DESCRIPTION	QTY	MATERIAL	REMARKS
FILE DIR: \\192.168.4.15\mechanical\Draft Nuryana\Proyek Pak Arifin\Bushing tilling\		SCALE: 1:2	DIM: mm	ASSY NO.
MECHANICAL ENGINEERING SECTION				
DIM: mm	NAME	DATE	SIGN	
DRAWN	ENDEN	16-Oct-18	[Signature]	
DESIGN	B.ARIFIN		[Signature]	
CHECK	YESSIKO		[Signature]	
APRV	M. NUGRAHA		[Signature]	
CANCEL DWG NO.				
REF DWG NO.				

TITLE CUTTING PLAN - TILTING  
**BUSHING CUTTING BOARD  
MOVEMENT**