

DETAIL B
SCALE 1 : 2

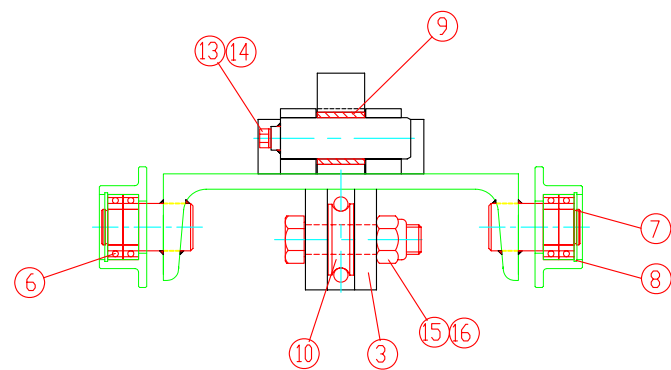

SECTION A-A
SCALE 1 : 2

Q'TY 1 SET

POS.	DESCRIPTION	QIT.	MATERAIL	REMARK
16.	SELF RETAINING NUT M24	2		
15.	HEXAGON SCREW M24x100L	2		
14.	SPRING WASHER ϕ 8	2		
13.	HEXAGON SCREW M8x20L	2		
12.	SPRING WASHER ϕ 20	2		
11.	HEXAGON SCREW M20x80L	2		
10.	WIRE ROPE THIMBLE SIDE 14	2		
9.	DILESS BUSH ϕ 35/44x36	2		
8.	RETAINING RING (INTERNAL) ϕ 55x2	8		
7.	RETAINING RING (EXTERNAL) ϕ 30x1.5	8		
6.	BEARING SKF "6006-2Z"	16		
5.	PUSHER WHEEL	8		SEE DWG. 10442519
4.	SHAFT	2		SEE DWG. 10442520
3.	ROPE RECEIVER	1		SEE DWG. 10442517
2.	PUSHING DEVICE	2		SEE DWG. 10442525
1.	PUSHER FRAME	1		SEE DWG. 10442524

DIR./FILE : . SCALE : 1:25 ASSY.No. : .

DIM....MM.	NAME	DATE	PROJECT.
DRAWN	WEERAPHOL P.	18/8/13	PUSHER CAR NO.3 (ASSEMBLY)
DESIGNED			
CHECKED			
APPROVED			

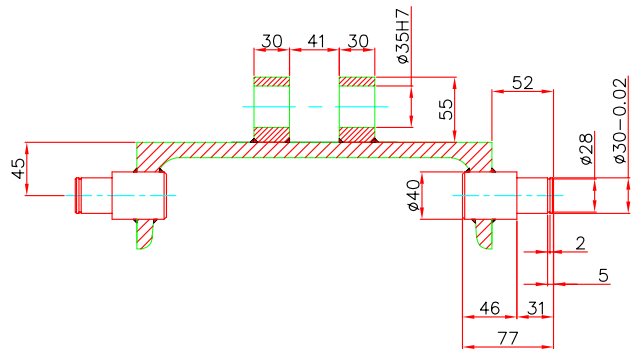
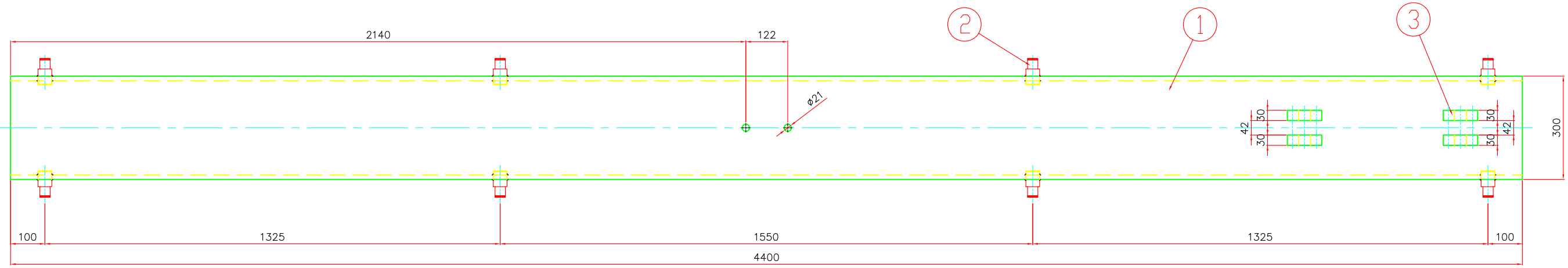
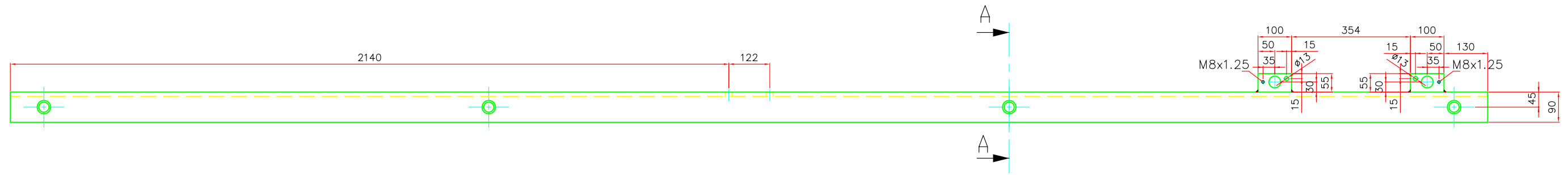

SEATION A-A
SCALE 1 : 2

Q'TY 1 SET

3.	STEEL PLATE 55X100X30t	4	SS400	
2.	SHAFT φ40X77	8	SS400	
1.	CHANNEL 300X90X9t = 4400L	1	SS400	
POS.	DESCRIPTION	QIT.	MATERAIL	REMARK
DIR./FILE : .		SCALE : 1:25		ASSY.No. : .
DIM....MM.	NAME	DATE	PROJECT. PUSHER FRAME PUSHER CAR NO.3	
DRAWN	WEERAPHOL P.	18/8/13		
DESIGNED				
CHECKED				
APPROVED				
PT. SCG LIGHTWEIGHT CONCRETE INDONESIA		A3	10442524	REV. NO. PAGE . 000

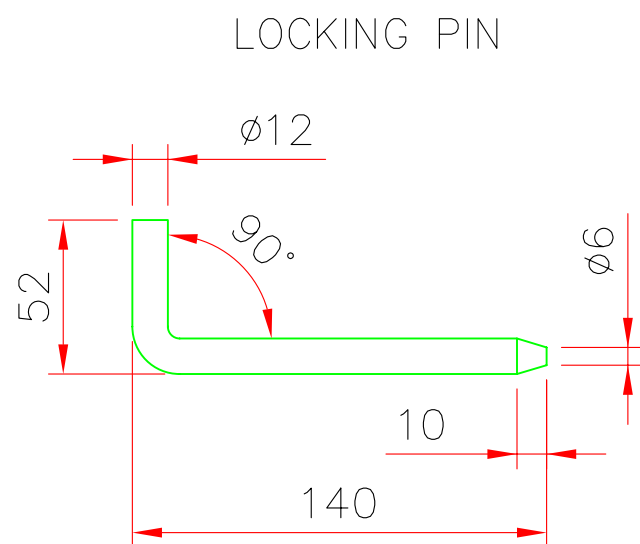
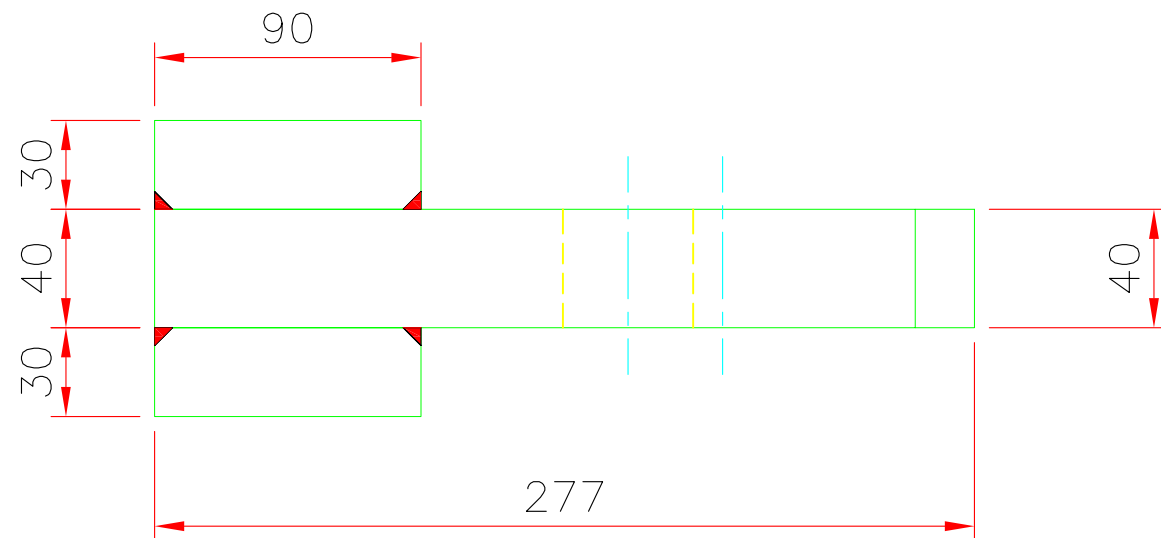
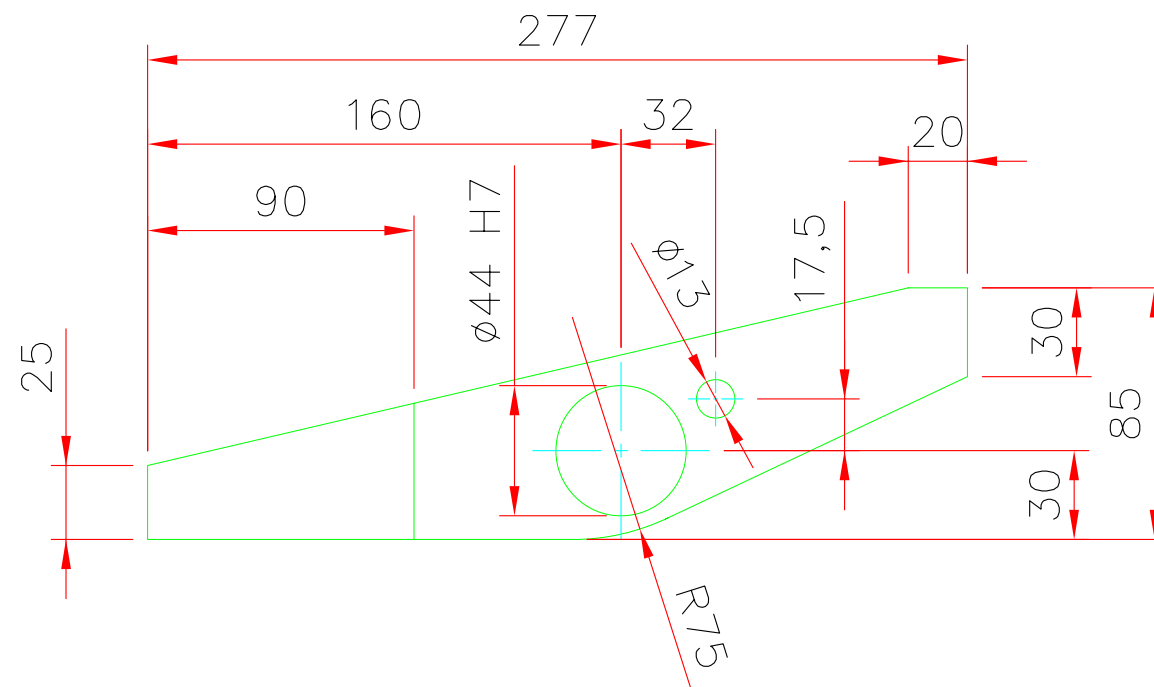

Q'TY 2 pcs.
MAT. : SS400

Q'TY 2 pcs.
MAT. : SS400

DIR/FILE : .			SCALE : 1:2	ASSY.No. : .
DIM...MM.	NAME	DATE	PROJECT. PUSHING DEVICE PUSHER CAR	
DRAWN	WEERAPHOL P.	18/8/13		
DESIGNED				
CHECKED				
APPROVED				
PT. SCG LIGHTWEIGHT CONCRETE INDONESIA			A3	10442525
			REV. NO.	PAGE
			.	000

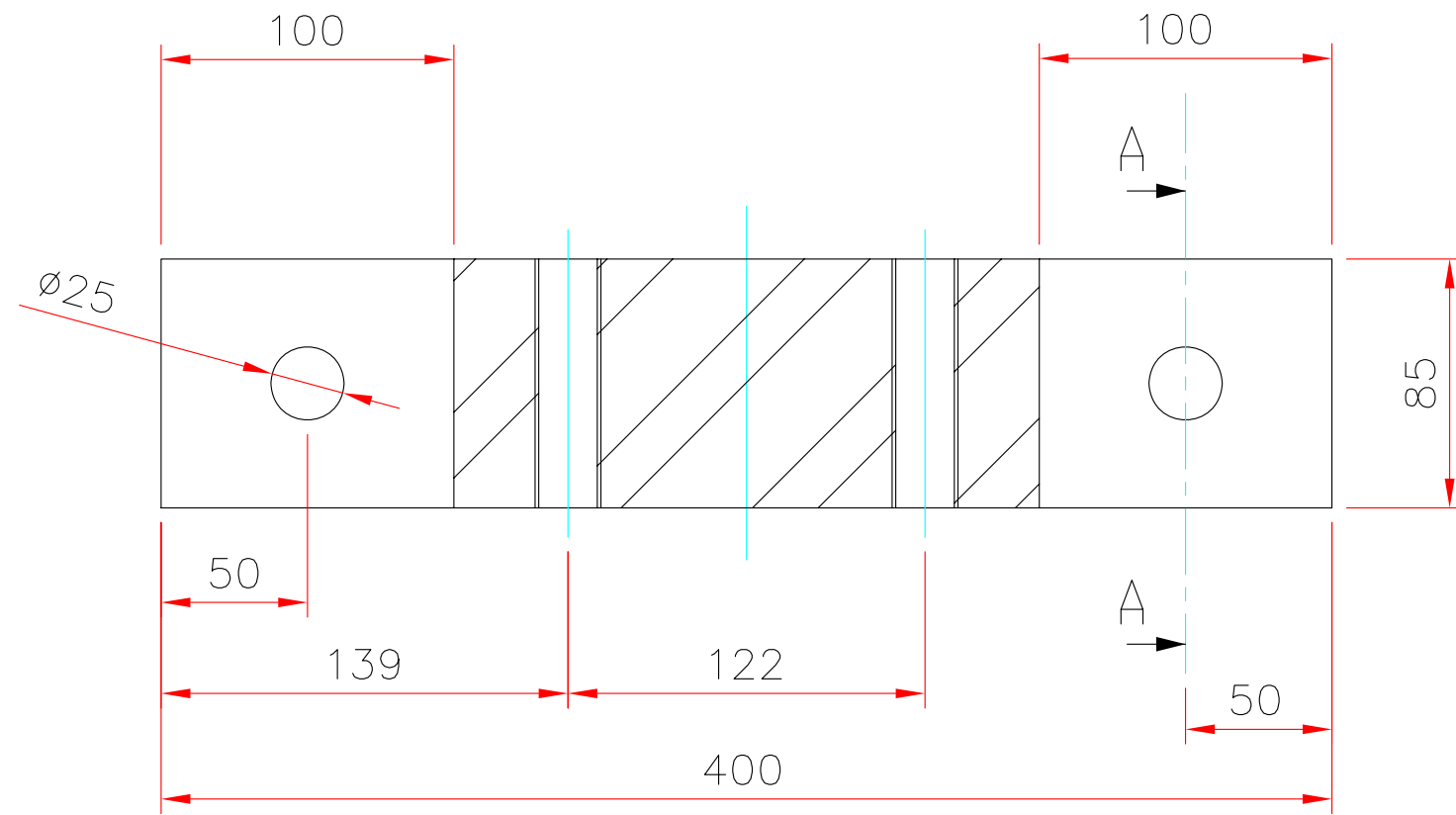

SECTION B-B

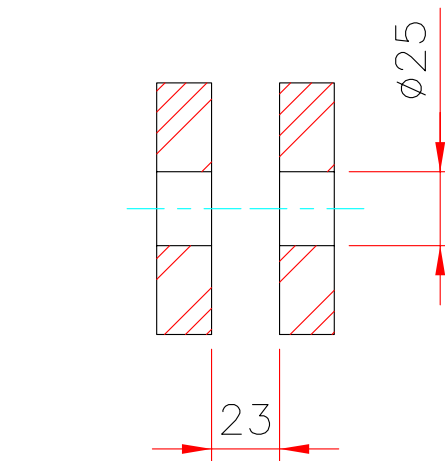

SECTION A-A

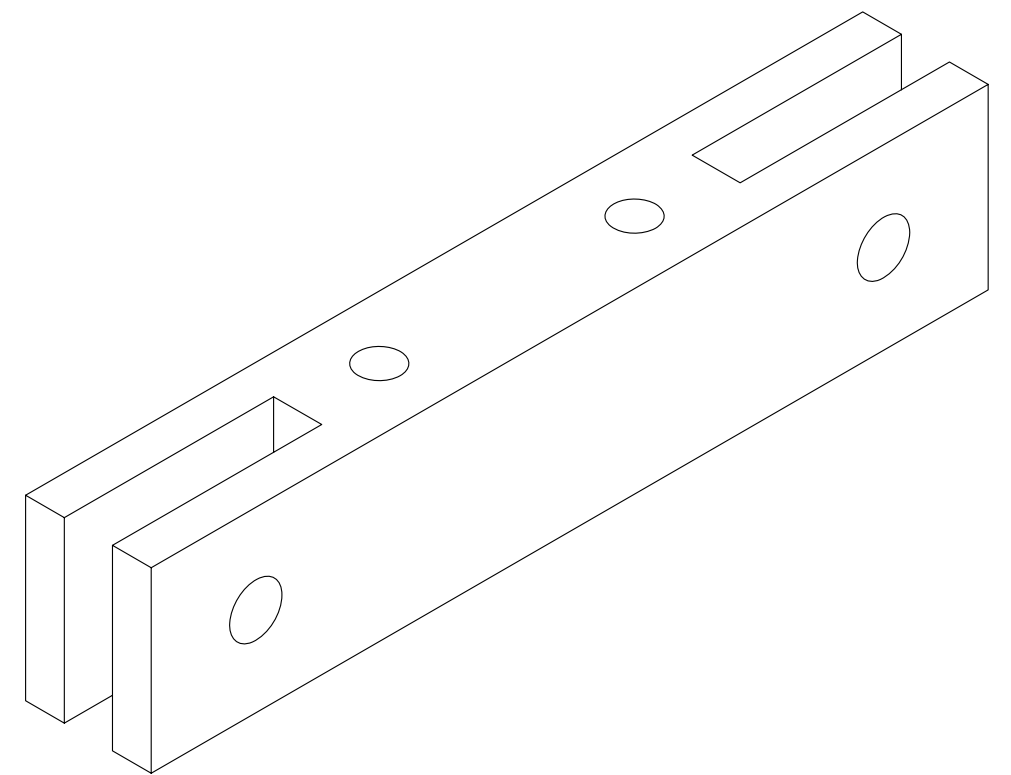
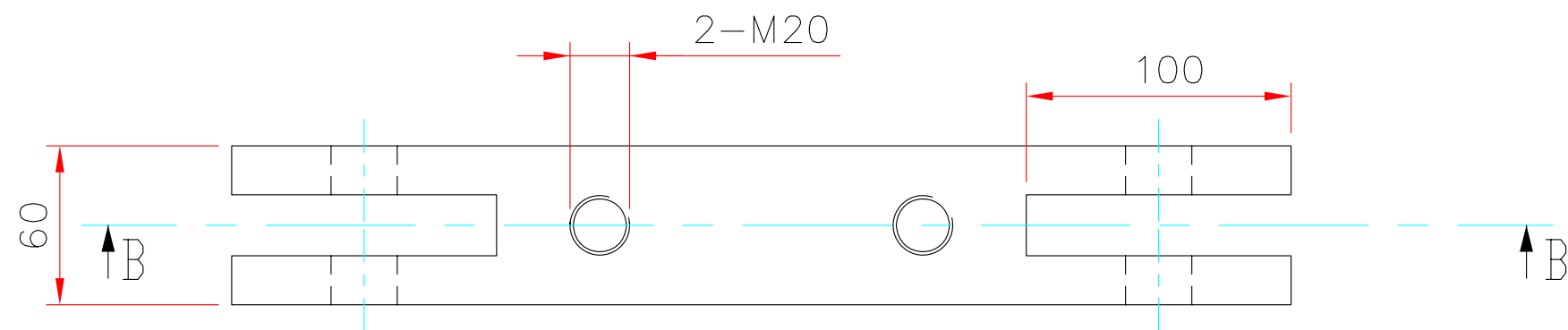

Q'TY 1 pcs.
MAT. : SS400

DIR./FILE : .		SCALE : 1:2	ASSY.No. : .
DIM....MM.	NAME	DATE	PROJECT. ROPE RECEIVER PUSHER CAR
DRAWN	WEERAPHOL P.	18/8/13	
DESIGNED			
CHECKED			
APPROVED			
PT. SCG LIGHTWEIGHT CONCRETE INDONESIA		A3	10442517
		REV. NO.	PAGE
		.	000

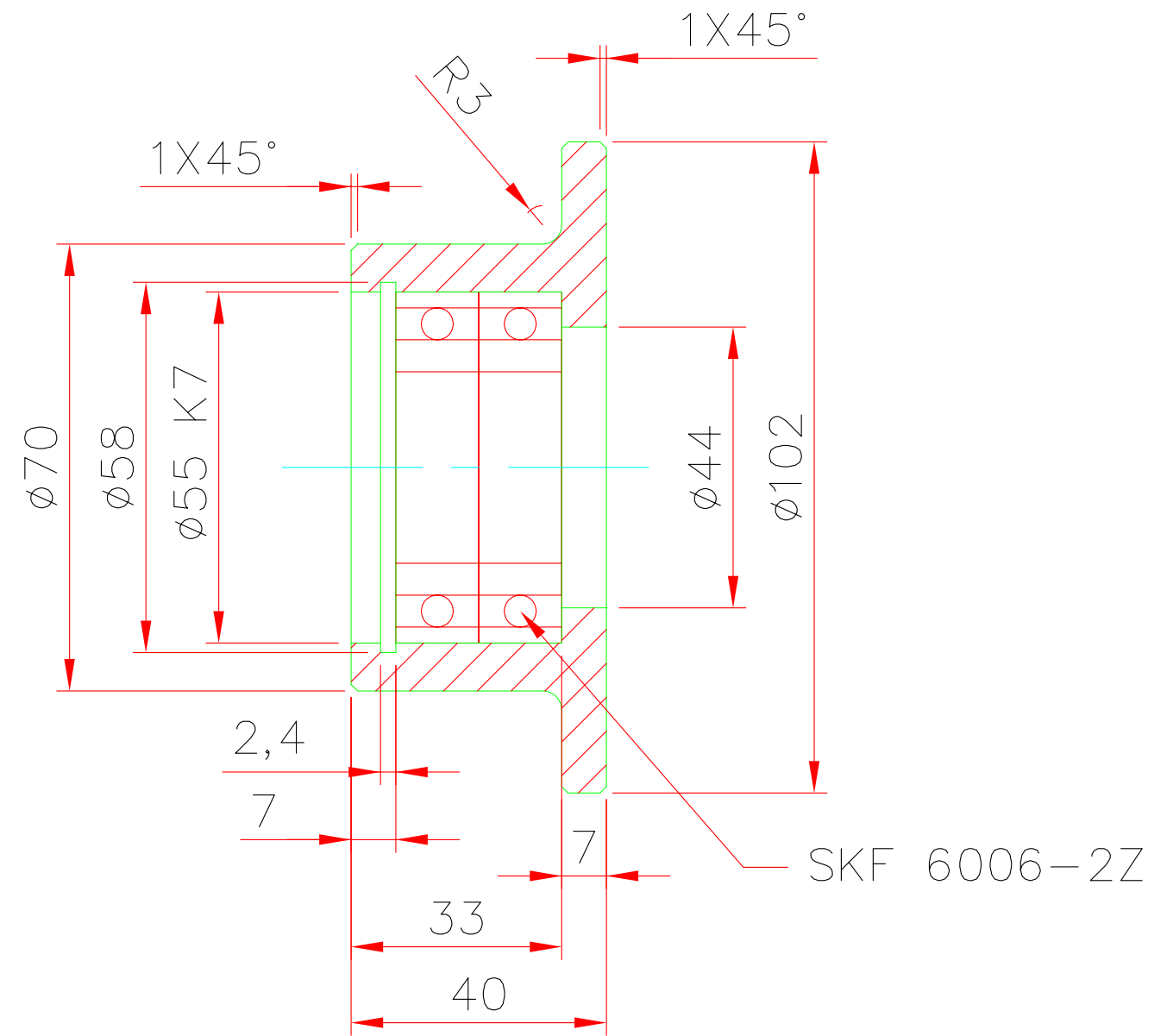
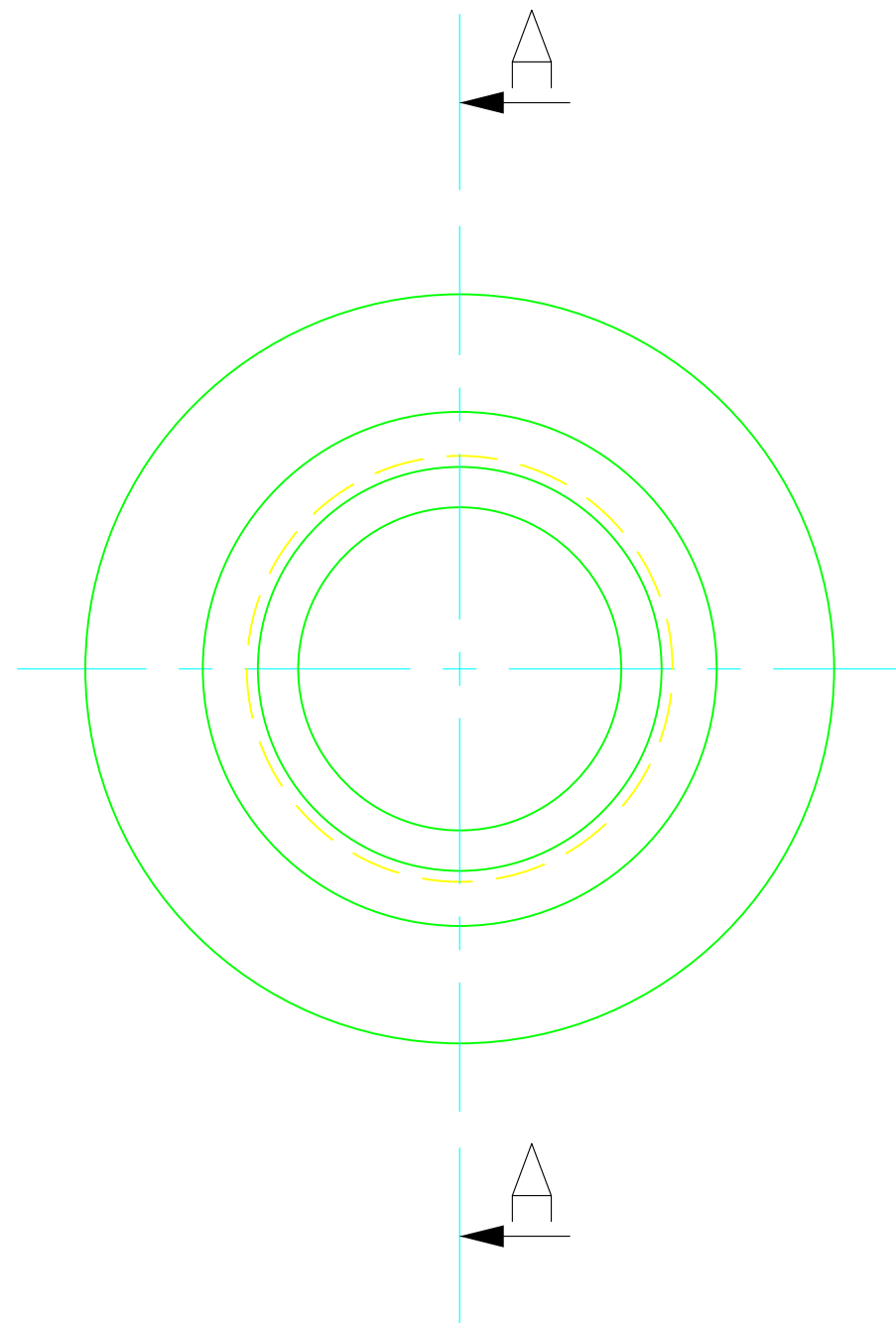

SECTION A-A

Q'TY 8 SET
MAT. : S45C

DIR./FILE : .			SCALE : 1:2	ASSY.No. : .
DIM...MM.	NAME	DATE	PROJECT. PUSHER WHEEL PUSHER CAR	
DRAWN	WEERAPHOL P.	18/8/13		
DESIGNED				
CHECKED				
APPROVED				
PT. SCG LIGHTWEIGHT CONCRETE INDONESIA			A3	10442519
			REV. NO.	PAGE
			.	000

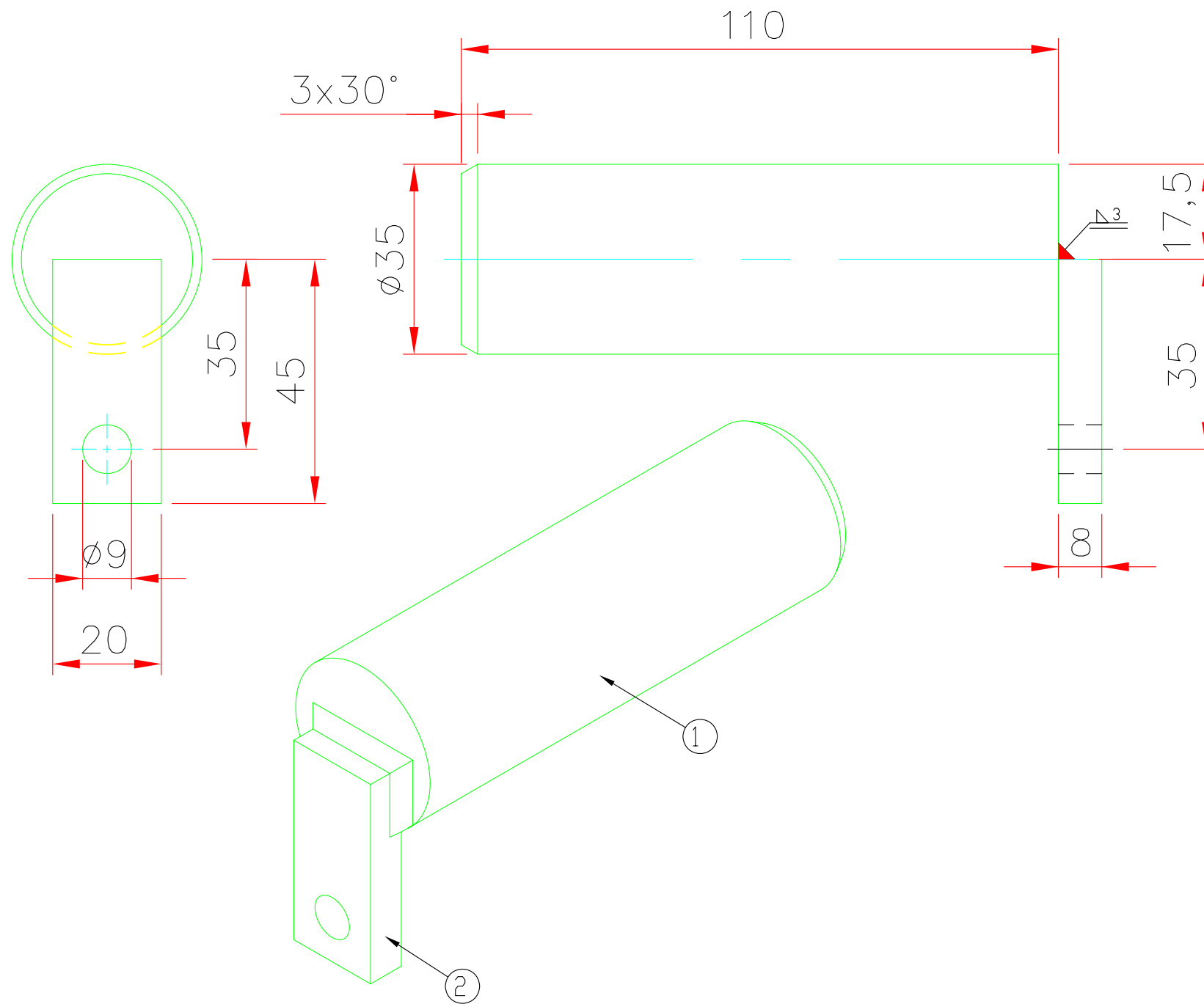

Q'TY 2 pcs.

2.	STEEL PLATE 20x45x8t	1	SS400	
1.	ROUND BAR ϕ 35x110L	1	S45C	
POS.	DESCRIPTION	QTY	MATERIAL	REMARK

DIR./FILE : .			SCALE : 1:2	ASSY.No. : .
DIM....MM.	NAME	DATE	PROJECT. SHAFT PUSHER CAR	
DRAWN	WEERAPHOL P.	18/8/13		
DESIGNED				
CHECKED				
APPROVED				