



PT. S.A.N JAYA TEKNIK

- SUPPLIER OF MACHINERIES PARTS
- GENERAL CONTRACTOR
- GENERAL TRADE

**SPH
SURAT PENAWARAN HARGA**

No SPH : 013/SPH/SJT/VI/2024
Tanggal : 28 Juni 2024

A. Biodata Workshop

PT. S.A.N Jaya Teknik

Jl. Sadang No. 164 Margahayu Bandung 40225

Telp : (022) 5405965, 5417604

Fax : (022) 5414583

Email : Marketing.sanjaya1@gmail.com

Website : www.sanjayateknik.com

Phone : 085156096651, 08122013957

B. Biodata Customer

Kepada Yth

Nama Perusahaan : **PT. SCG Lightweight Concrete Ind.**

Alamat : Surya Cipta City of Industry

Karawang - Indonesia

Telp. : (0267) 8610 362, 8610 363

Fax : (0267) 8610 360

Email :

Person : **Bpk. Arfandi**

Dengan Hormat,

Berikut ini kami sampaikan penawaran harga untuk barang berikut dibawah ini :

C. Biodata Pekerjaan

Jenis Pekerjaan : Manufaktur Fabrikasi Repair Modifikasi

Sub Bidang : Part/Komponen Sub Assy Complete Assy

No.	Nama Barang	Qty	Sat	Harga Satuan (Rp)	Jumlah Harga (Rp)
1	LONG ELBOW PIPE 80D PALM KERNEL	1	PCS	9,100,000 7.920.000	9,100,000
				Jumlah	9,100,000
				PPN 11%	1,001,000
				Total	10,101,000

Terbilang: Sepuluh Juta Seratus Seribu Rupiah

Spesifikasi/Dimensi/Keterangan

Spesifikasi:

- Pipa 4" Steel SCH 80

- Flange JIS 4" 5k

Ruang Lingkup kerja Umum (RLKU)

- Inspeksi Awal,
- Diskusi Teknik,
- Pengadaan material,
- Proses Produksi

Konfir masi Harga ke bu pyar 12/4/24

Ruang Lingkup Kerja Produksi (RLKP)

- Roll Pipa
- Turning Flange
- Welding
- Setting

D. Sketsa / Catatan

1. TOLERANSI DIMENSI DAN GEOMETRIS SESUAI DENGAN STANDARD ISO
2. PT. Sanjaya Teknik akan mengajukan addendum harga apabila ada pekerjaan diluar ruang lingkup pekerjaan diatas dengan surat penawaran harga terpisah

Demikian surat penawaran harga ini kami sampaikan, dan kami tunggu kabar baik selanjutnya. Atas perhatian, kepercayaan dan kerjasamanya yang baik selama ini, kami ucapkan terima kasih.

E. Ketentuan

Proses Kerja :
 Pembayaran :
 Down Payment (DP) :
 Validasi Penawaran : 1 Minggu
 Keterangan : Pekerjaan setelah DP, PO/SPK diterima

Dibuat Oleh,

Ditandatangani Oleh,

(Pijar Alfia N.)



(Nandang Sopihan)

ward To :

PT SCG Lightweight Concrete Indonesia
Jl. Surya Tekno, Kawasan Industri Surya Cipta KAV I-T1-3, Kutamekar
Kec, Ciampel, Karawang, Jawa Barat 41363

Phone :

Fax :

QUOTATION

QO No : M2310240001

Date : October 24, 2024

pped To :

PT SCG Lightweight Concrete Indonesia
Jl. Surya Tekno, Kawasan Industri Surya Cipta KAV I-T1-3, Kutamekar
Kec, Ciampel, Karawang, Jawa Barat 41363

Phone :

Fax :

Email :

Attention to :

Mr Yoki

Our Ref. :

From / Sales Engineer :

Name : Muzi

Phone : 085771559233

Fax : 021-85508574

Email : Muzi@sjj-nusantara.com

quote you the followings :

No	Descriptions	Qty	Unit	Unit Price (IDR)	Amount (IDR)
1	Supply & fabricate for Bend Pipe R9.144	1	PCS	8.000.000	8.000.000
	Material :				
1	CS Pipa 4" Sch.40 "Welded"				
2	MS Plate Stopper Flange 5 mm				
3	SO Flange JIS 4"				
	Notes :				
	Harga belum termasuk bolt & nut				
	Harga sudah termasuk painting				

Delivery Time : 2-3 minggu

Delivery Terms : Franco Your Ware House

Payment Terms : COD

Validity : 30 days from date of quotation.

IMPT : Price quoted is based on the quantity stated above in one order.

Sub Total :	8.000.000
Discount % :	0
DPP (After Discount) :	8.000.000
VAT % :	880.000
Freight :	0
Grand Total :	8.880.000

We hope this offer meets your expectations and we are looking forward to receive your order.
You can rest assured that your order will be came out to your entire satisfaction.

Notes :

Bekasi,

October 24, 2024

Your Sincerely,

Muzi

Sales Engineering



PT. BEST FLOW SYSTEM



QUOTATION

QUO-BTF-24/10/00200

Attention :

PT.SCG LIGHTWEIGHT CONCRETE INDONESIA
JL.SURYA TEKNO KAV I-T1-3 SURYACIPTA CITY OF INDUSTRIES
BLOK - NO. - RT:000 RW:000 KEL.KUTAMEKAR
Telp. 0267-8610361
Fax.

Date : 15-October-2024
Reference : E-INQUIRY EMAIL
Currency : IDR
Validity : 1 Week
Sales in charge : RIA
TOP : 30 Hari

Table with 7 columns: NO, DESCRIPTION, QTY, UOM, Delivery, UNIT PRICE, TOTAL PRICE. Row 1: FABRIKASI LONG ELBOW PIPE 80D PALM KARNEL, 1, UNIT, 2 WEEKS, 16.605.000,00, 16.605.000,00

Catatan (Remarks) :
FRANCO KARAWANG

Summary table: Sub Total : 16.605.000,00; Discount : 0.00; PPN (V.A.T) : 1.826.550,00; Grand Total : 18.431.550,00

RIA

KAWASAN PERGUDANGAN DAN INDUSTRI DAAN MOGOT ERA PRIMA
JL.DAAN MOGOT KM 21 N-31 NO.31 RT.004 RW.005 PORIS PLAWAD CIPONDOH
NO TELP : 021-55727715/16, 021-55727831
NPWP : 02.751.238.3-039.000



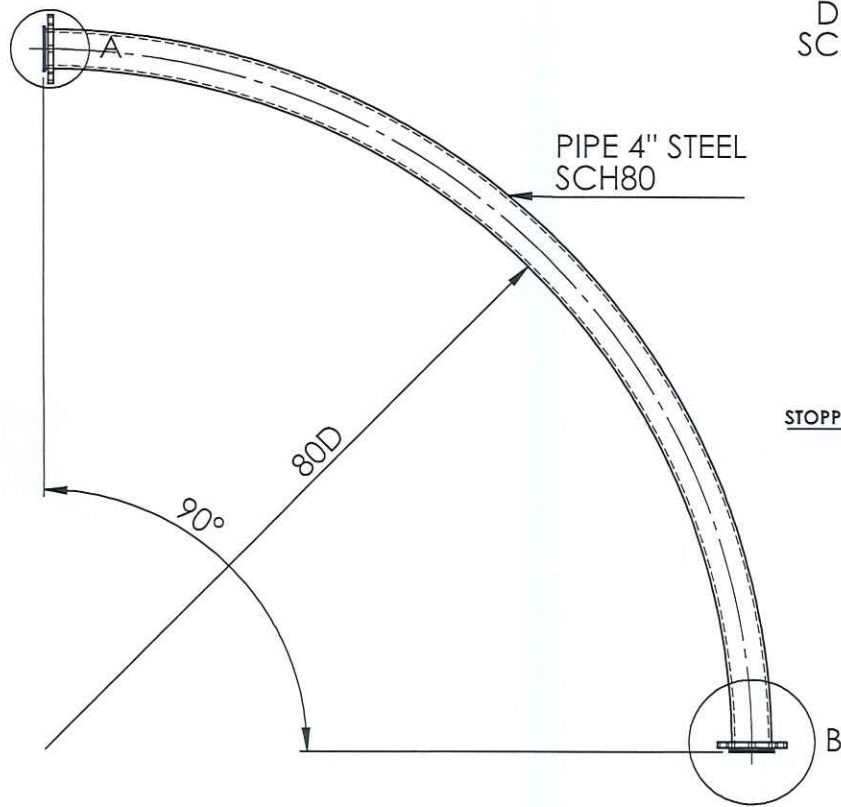

DETAIL A
SCALE 1 : 5

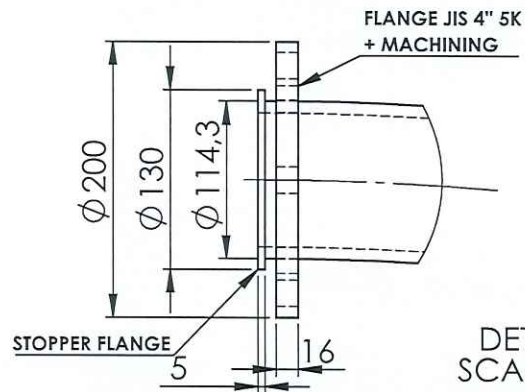

DETAIL B
SCALE 1 : 5

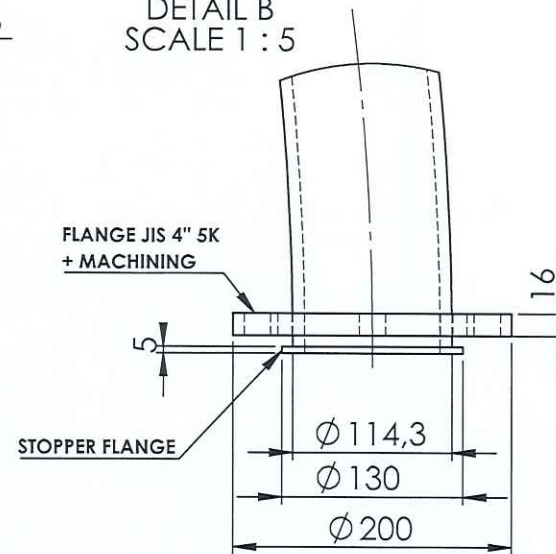

NOTE:
PIPE STEEL 4" : OD-114.3MM : ID-97.1MM

** INCOMING PART WILL BE CHECK. IT WILL RETURN IF NOT PASS **

POLISHING	GRINDING	NORMAL MACHINING (SMOOTH SURFACE)	NORMAL MACHINING (ROUGH SURFACE)
▽▽▽▽	▽▽▽	▽	▽

1	LONG ELBOW PIPE 80D PALM KERNEL	1	SS-400	
POS	DESCRIPTION	QTY	MATERIAL	REMARKS
FILE DIR: D:\SOLIDWORKS 2018\Project\Modifikasi Pipa Cangkang\		SCALE: 1:50		ASSY NO.
DIM: mm		MECHANICAL ENGINEERING SECTION		
DRAWN	ROBBY	DATE	18/06/2024	
DESIGNED	ROBBY	TITLE		
CHECKED	MOECHLIS	<p style="text-align: center;">LONG ELBOW PIPE 80D PALM KERNEL</p>		
APPROVED	MOECHLIS			
CANCEL DWG NO.				
REF DWG NO.				