

**Display Purchase Req. 1021012013**

Document Overview On Personal Setting

2010 PR frm MRP/CBP 1021012013

Header

Default Values

Requisn Date	St...	Item A I M	Short Text	Quantity	Unit	Delivery Date	P...	Requisitioner	Matl Group	Plant	Stor. Loc.	Purch. Grp	Total Value
02.06.2022		10 K	Housing Feeding Screw Palm Kernel	1	PC	28.06.2022	1	Taufik	Supplies	PT SLCI		DBA	12,000,000

Item [ 10 ] Housing Feeding Screw Palm Kernel

Material Data | Quantities/Dates | Valuation | Account Assignment | Source of Supply | Status | Contact Person | Texts | Delivery Address | Spec2000 / SC

Item Texts	A...	
•  Item text	<input checked="" type="checkbox"/>	Purpose : [10] Feeding Screw Palm Kernel, Details : 2012-DWG-BAC-SC-M-001-A
•  Item note	<input type="checkbox"/>	
•  Delivery text	<input type="checkbox"/>	GL : 523072
•  Material PO text	<input type="checkbox"/>	CC : 2011-10000

Continuous-tex...

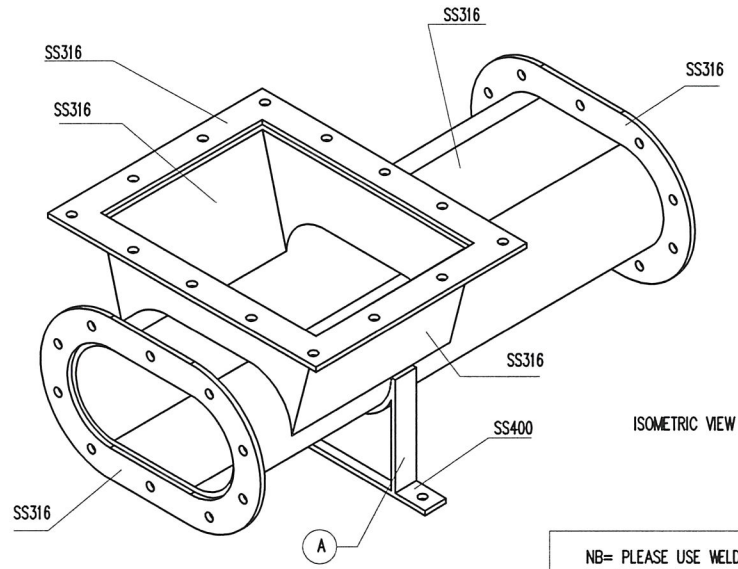
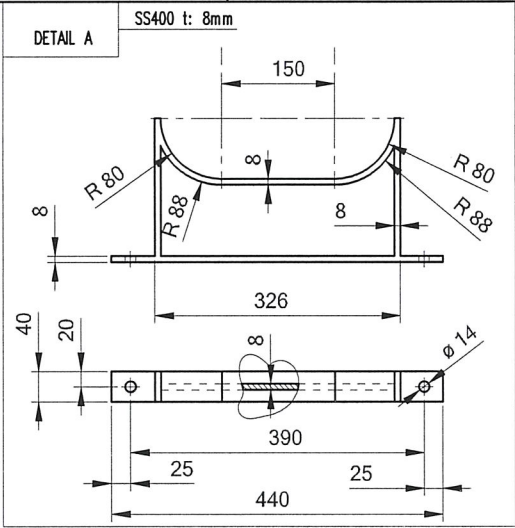
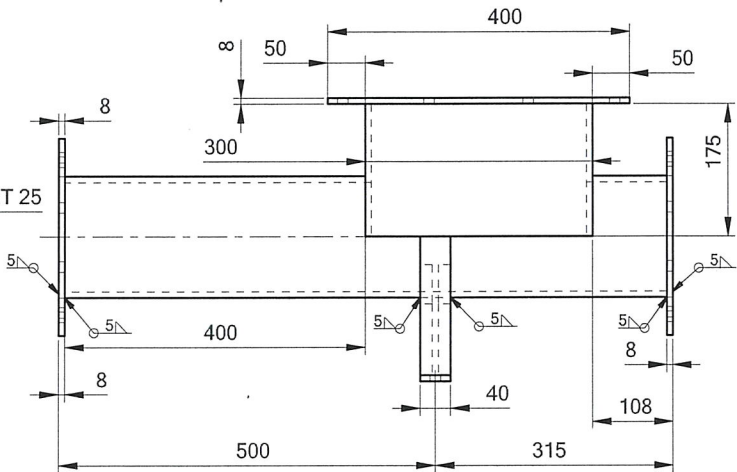
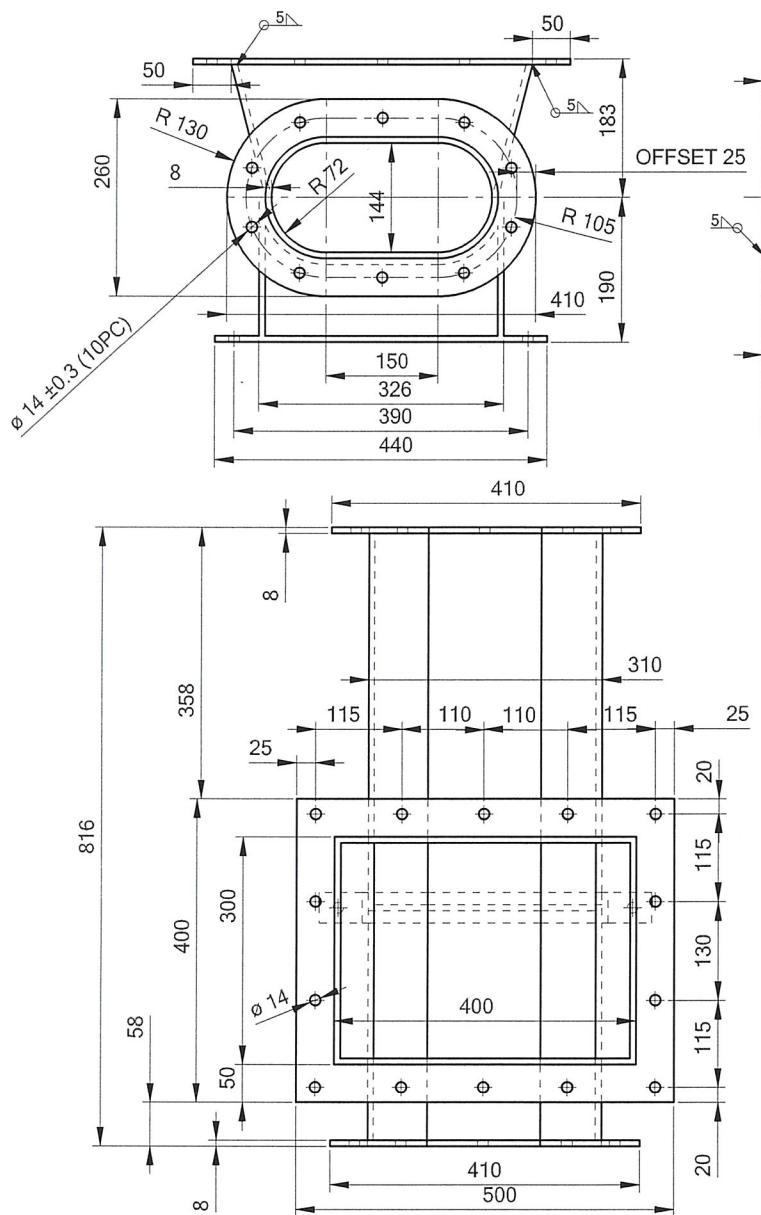

NB= PLEASE USE WELDING SPECIFICATIONS FOR STAINLESS STEEL  
EX: TIG WELDING

\*\* INCOMING PART WILL BE CHECK. IT WILL RETURN IF NOT PASS \*\*

POLISHING	GRINDING	NORMAL MACHINING (SMOOTH SURFACE)	NORMAL MACHINING (ROUGH SURFACE)
▽▽▽	▽▽	▽	▽

1	HOUSING SCREW	1	STAINLESS STEEL+SS 400	-
POS	DESCRIPTION	QTY	MATERIAL	REMARKS
FILE DIR: -		SCALE: 1:10		DIM: mm
DIM: mm		MECHANICAL ENGINEERING SECTION		
DRAWN	ENDEN	DATE	11/JULY/19	TITLE BOILER AND AUTOCLAVE - SCREW PALM KERNEL
DESIGN	ARIEF H	SIGN		
CHECK	YESSIKO	SIGN		
APRV	MANURAH	SIGN		
(*) = GENERAL TOLERANSI ±0.2% x DIMENSION				
REF DWG NO.				

### HOUSING SCREW