

Display Purchase Req. 1021012015

Document Overview On | Personal Setting

2010 PR frm MRP/CBP | 1021012015

Header

Default Values

Requisn Date	St...	Item	A	I	M	Short Text	Quantity	Unit	Delivery Date	P...	Requisitioner	Matl Group	Plant	Stor. Loc.	Purch. Grp	Total Value
02.06.2022		10	K			Making U-Piping Palm kernel	1	PC	20.07.2022	1	Taufik	Supplies	PT SLCI		DBA	4,600,000

Item [10] Making U-Piping Palm kernel

Material Data | Quantities/Dates | Valuation | Account Assignment | Source of Supply | Status | Contact Person | **Texts** | Delivery Address | Spec2000 / SC

- Item Texts A...
- Item text
 - Item note
 - Delivery text
 - Material PO text

Purpose :
 [10] Piping Silo Palm Kernel, Details : 2012-DWG-BAC-PP-M-010-3

 GL : 523072
 CC : 2011-10000

Continuous-tex... ▼

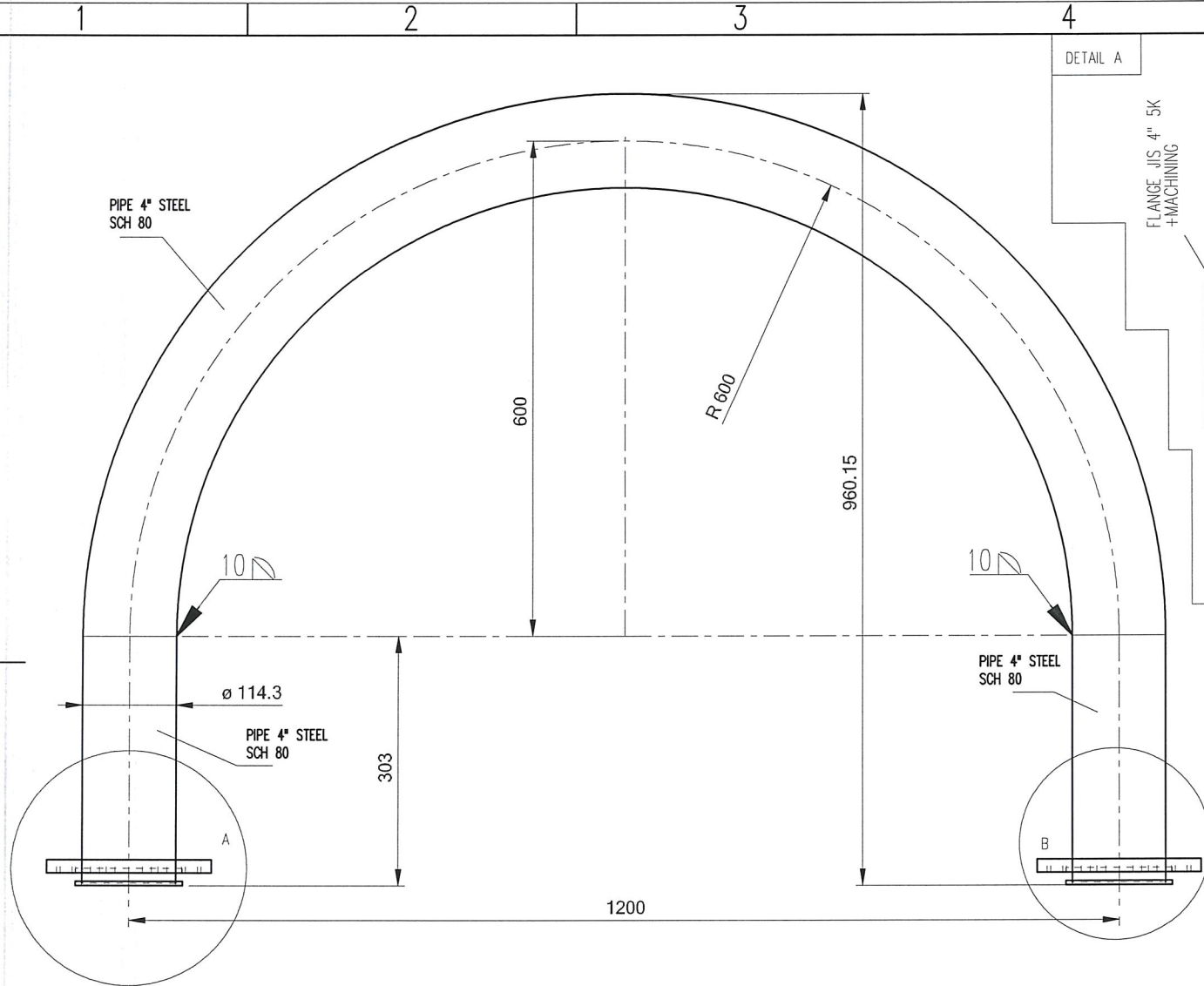

DETAIL A

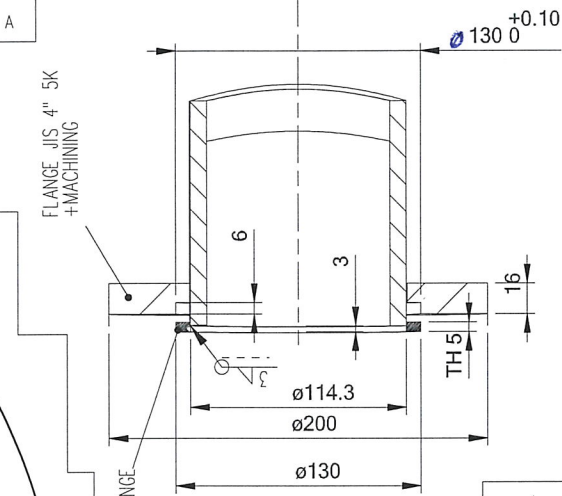

DETAIL B

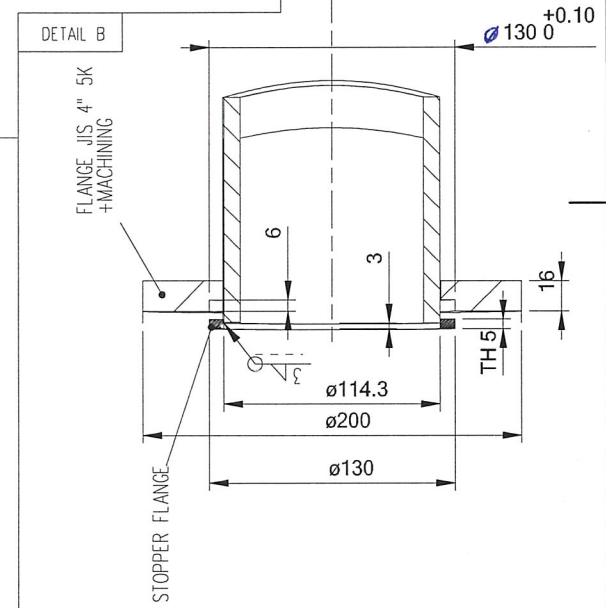

NOTE: PIPE STEEL $\phi 4\"$: OD-114.3mm : ID-97.1mm

** INCOMING PART WILL BE CHECK. IT WILL RETURN IF NOT PASS **

POLISHING	GRINDING	NORMAL MACHINING (SMOOTH SURFACE)	NORMAL MACHINING (ROUGH SURFACE)
▽▽▽	▽▽	▽	▽

1	U-PIPING PALM KERNEL	1	SS-400	
POS	DESCRIPTION	QTY	MATERIAL	REMARKS
FILE DIR:		SCALE: 1:8		ASSY NO.
DIM: mm		MECHANICAL ENGINEERING SECTION		
DRAWN	NAME	DATE	SIGN.	TITLE BOILER AND AUTOCLAVE - PIPING
DESIGN	S. HUDA	14/JAN/21	[Signature]	U-PIPING PALM KERNEL
CHECK	TAUFIQ	19/10/21	[Signature]	
APRV	M. NUGRAHA		[Signature]	
() = GENERAL TOLERANSI $\pm 0.2\%$ x DIMENSION REFF DWG NO. -				