

**Display Purchase Req. 1021012017**

Document Overview On | Personal Setting

2010 PR frm MRP/CBP | 1021012017

Header

Default Values

Requisn Date	St..	Item	A	I	M	Short Text	Quantity	Unit	Delivery Date	P...	Requisitioner	Matl Group	Plant	Stor. Loc.	Purch. Grp	Total Value
02.06.2022		10	K			Connecting link Dia.22mm with nut	70	PC	06.09.2022	1	Taufik	Supplies	PT SLCI		DBA	35,000,000

Item [ 10 ] Connecting link Dia.22mm with nut

Material Data | Quantities/Dates | Valuation | Account Assignment | Source of Supply | Status | Contact Person | **Texts** | Delivery Address | Spec2000 / SC

Item Texts	A...	
•  Item text	<input checked="" type="checkbox"/>	Purpose : [10] Replacement chain bucket elevator, last replacement Dec 2021. Details : 2012-DWG-RMA-BE01-M-110  GL : 523072 CC : 2011-10000
•  Item note	<input type="checkbox"/>	
•  Delivery text	<input type="checkbox"/>	
•  Material PO text	<input type="checkbox"/>	

Continuous-tex...

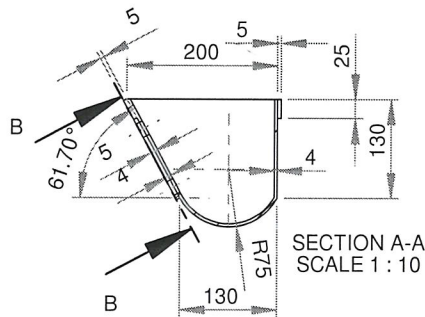
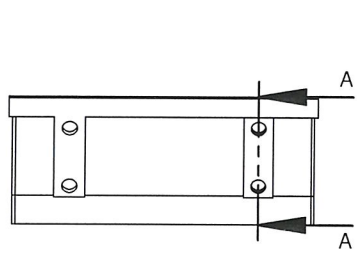

SECTION A-A  
SCALE 1 : 10

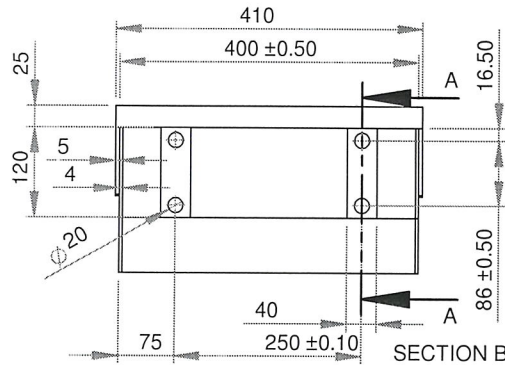

SECTION B-B  
SCALE 1 : 10

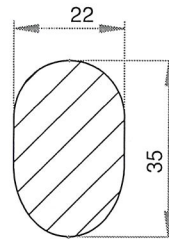

SECTION E-E  
SCALE 2 : 3

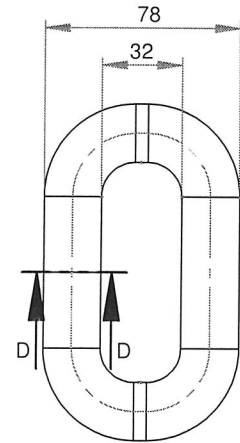

SCALE 1:3

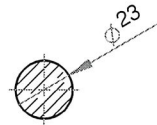

SECTION D-D  
SCALE 1 : 3

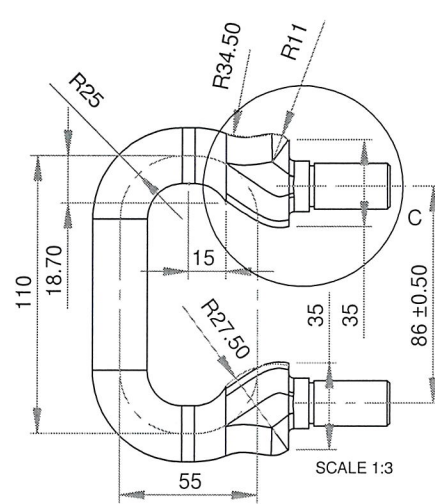

SCALE 1:3

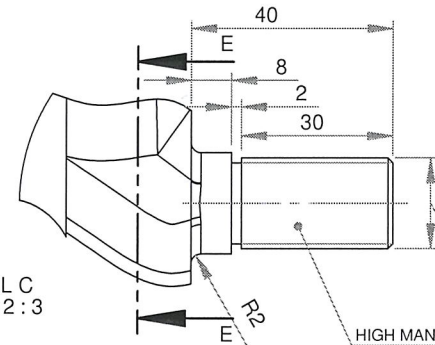

DETAIL C  
SCALE 2 : 3

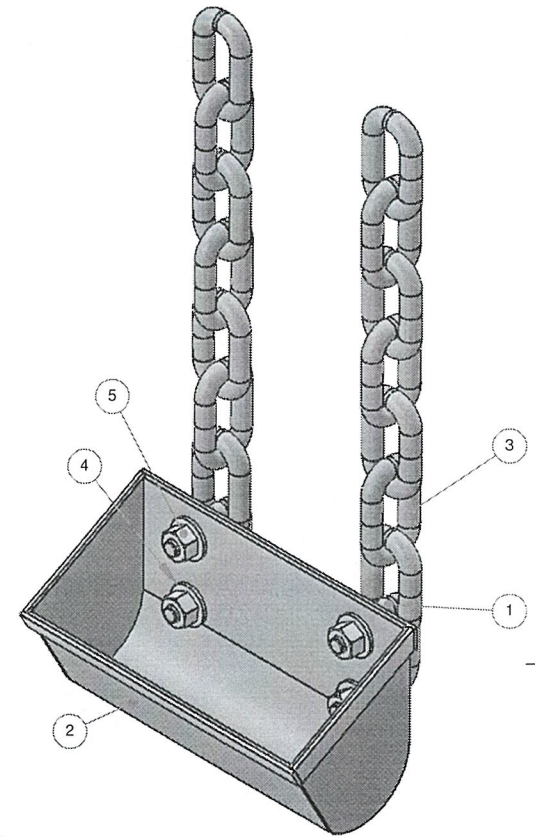

ISOMETRIC VIEW  
SCALE 1:8

POS	DESCRIPTION	QTY	MATERIAL	REMARKS
5	NUT M18x2.5	2	HTBN 8.8	-
4	WASHER PLATE M18	2	SPRING STEEL	-
3	CHAIN EYE	14	HIGH MANGANESE STEEL (FORGING)	CASTING PROCESS WILL BE ACCEPTABLE
2	BUCKET	1	ANTI WEAR PLATE	HARDOX 500 OR COMPATIBLE
1	LOCKING CHAIN	2	HIGH MANGANESE STEEL (FORGING)	CASTING PROCESS WILL BE ACCEPTABLE

FILE DIR: \\192.168.4.15\mechanical\Draft Nuryana\Proyek Pak Yessiko\Bucket elevator\		SCALE: 1:20	DIM: mm	ASSY NO.
DIM: mm	NAME			

DRAWN	ENDEN	03-Sep-18	MECHANICAL ENGINEERING SECTION
DESIGN	AVAILABLE	Ulanha 3/19.18	
CHECK	YESSIKO		
APRV	M. NUGRAHA		
CANCEL DWG NO.			

TITLE BUCKET ELEVATOR 01

# ASSEMBLY SEVEN CHAIN LINK (EXISTING)

\*\* INCOMING PART WILL BE CHECK. IT WILL RETURN IF NOT PASS \*\*

POLISHING	GRINDING	NORMAL MACHINING (SMOOTH SURFACE)	NORMAL MACHINING (ROUGH SURFACE)
▽▽▽	▽▽	▽	▽

1

2

3



PT SCG LIGHTWEIGHT CONCRETE INDONESIA

A4

2012-DWG-RMA-BE01-M-110

REV NO. PAGE

1