

# Display Purchase Req. 1021012573

Document Overview On Personal Setting

2010 PR frm MRP/CBP 1021012573

Header

Default Values

Requisn Date	Status	Item	A	I	Material	Short Text	Quantity	Unit	Delivery Date	Per	Requisnr.	Material Group	Plant	Stor. Loc.	PGr	Total Value
28.09.2022		10	K			Cam Cross Cutter Type A [20...	3	PC	28.10.2022	1	Taufik	Supplies	PT SLCI		DBA	1,800,000
28.09.20...		20	K			Cam Cross Cutter Type B [20...	3	PC	28.10.2022	1	Taufik	Supplies	PT SLCI		DBA	1,800,000

Item [ 10 ] Cam Cross Cutter Type A [2012-DWG-C...

Material Data
Quantities/Dates
Valuation
Account Assignment
Source of Supply
Status
Contact Person
Texts
Delivery Address
Spec2000 / SC

Item Texts	A...	
•  Item text	✓	Purpose:  Cross Cutter [Last Install: January 2021]  GL: 523072 CC: 2011-10000
•  Item note		
•  Delivery text		
•  Material PO text		

Continuous-tex...

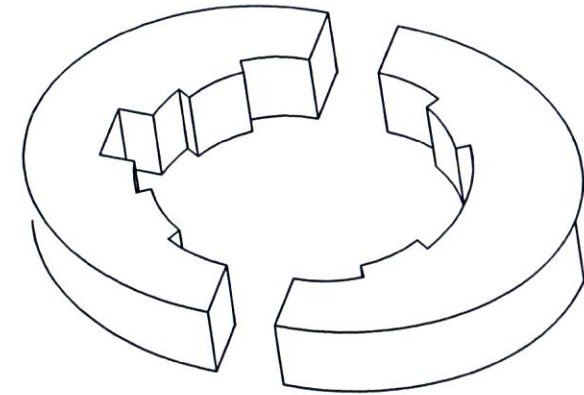
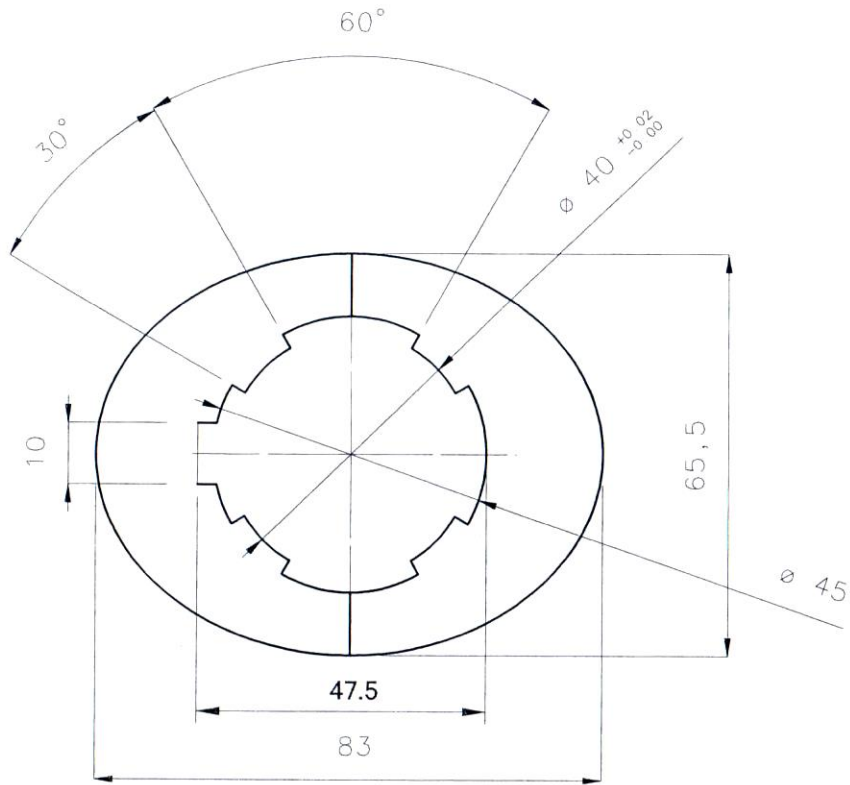

Isometric view

**\*Material VCN 150**  
**\*Hardening 50 HRC**

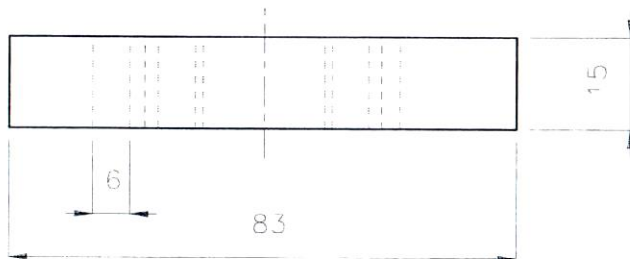

1	Cam cross Cutter	1	VCN 150	-
No	Description	Qty	Material	Remarks
	DIR/File:C:\Spiderman\Desktop\SLC\Project varicad\ cam cross cutter		Scale	Assy No.
DIM : mm		Name	Date	 <b>Cross Cutter</b> <b>Cam Cross Cutter</b> <b>TYPE B</b>
Drawn		Sigit	26 augst'15	
Designed				
Checked		Bp.Rully	20-10-16	
Approved		Bp.Nugi		
DIM : mm				
PT.SCG Lightweight concrete Indonesia		A4	2012-DWG-WKB-CC B-002	Rev No.
				Page 02

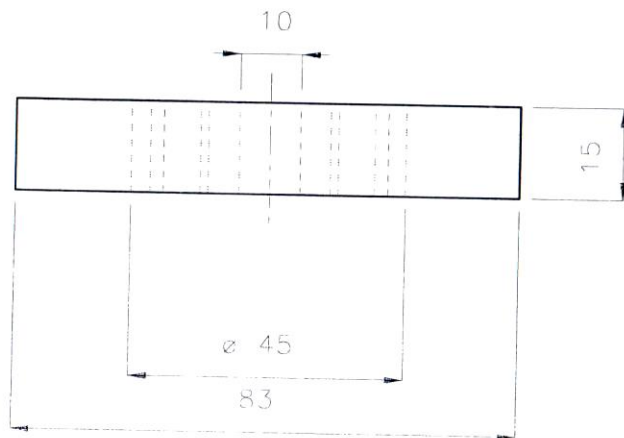
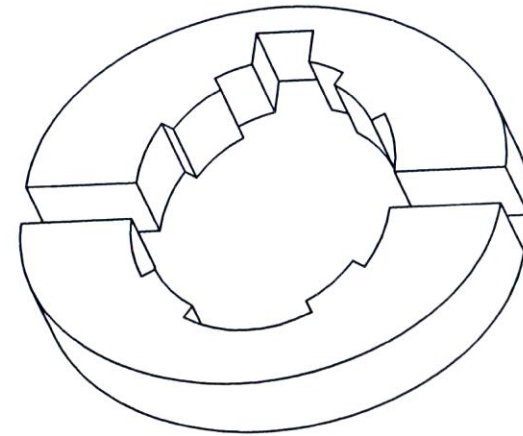
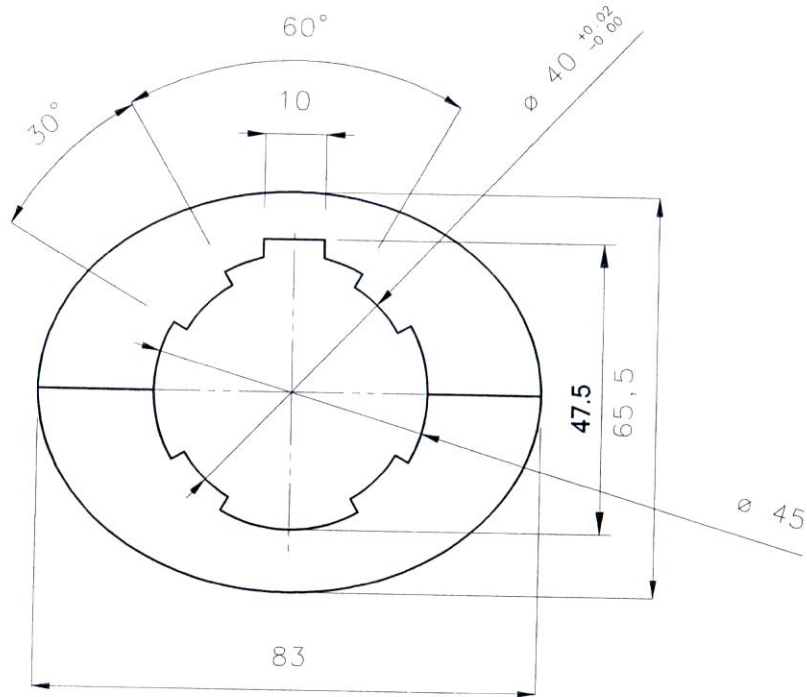

\*Material VCN 150  
\*Hardening 50 HRC

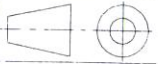
1	Cam cross Cutter	1	VCN 150	-
No	Description	Qty	Material	Remarks
	DIR/File:C:\Spiderman\Desktop\SLC\Project varicad\ cam cross cutter		Scale	Assy No.
DIM : mm	Name	Date	 <p>Cross Cutter <b>Cam Cross Cutter</b> TYPE A</p>	
Drawn	Sigit	26 august'15		
Designed				
Checked	Bp.Rully	20-10-16		
Approved	Bp.Nugi			
DIM : mm				
PT.SCG Lightweight concrete Indonesia		A4	2012-DWG-WKB-CC B-001	Rev No.
				Page 01