

Display Purchase Req. 1021012932

Document Overview On Personal Setting

2010 PR frm MRP/CBP ▾ 1021012932

Header

Default Values

Requisn Date	Status	Item	A	I	Material	Short Text	Quantity	Unit	Delivery Date	Per	Requisnr.	Material Group	Plant	Stor. Loc.	PGr	Total Value
09.01.2023		10	K			Mech Seal TV-61 Pump	1	ST	28.02.2023	1	Taufik	Supplies	PT SLCI		DBA	7,200,000

Item [10] Mech Seal TV-61 Pump

Material Data | Quantities/Dates | Valuation | Account Assignment | Source of Supply | Status | Contact Person | Texts | Delivery Address | Spec2000 / SC

Item Texts	A...	
Item text		<p>Purpose: Making Mechanical Seal Set Arrangement for TV-61 Pump</p> <p>GL: 523072 CC: 2011-10000</p>
Item note		
Delivery text		
Material PO text		

Continuous-tex... ▾

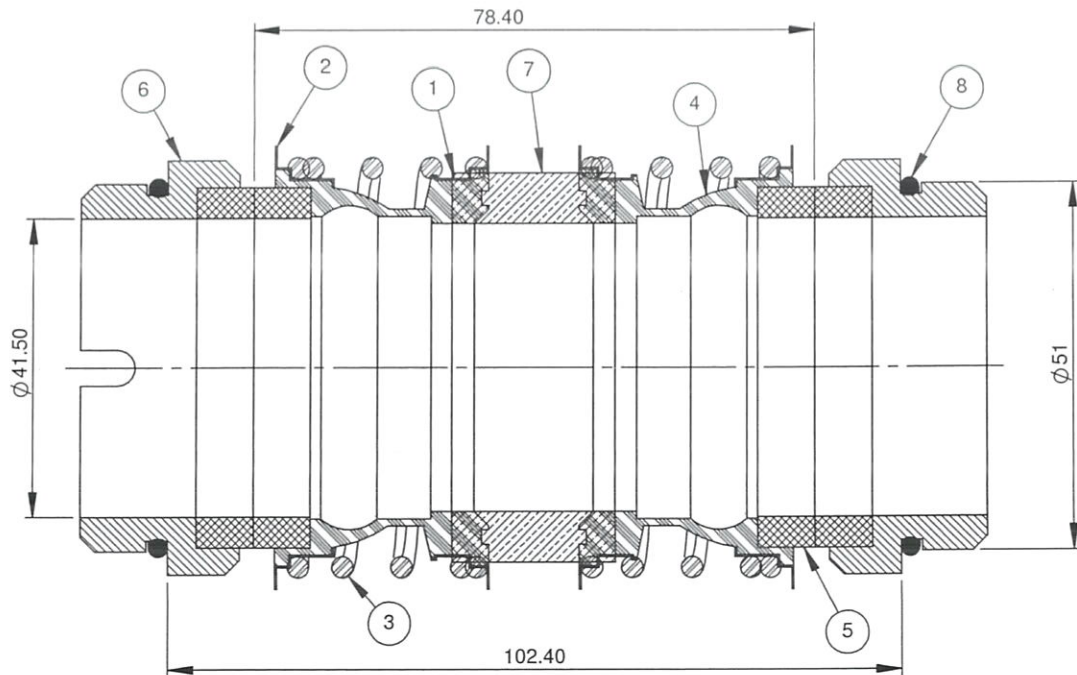
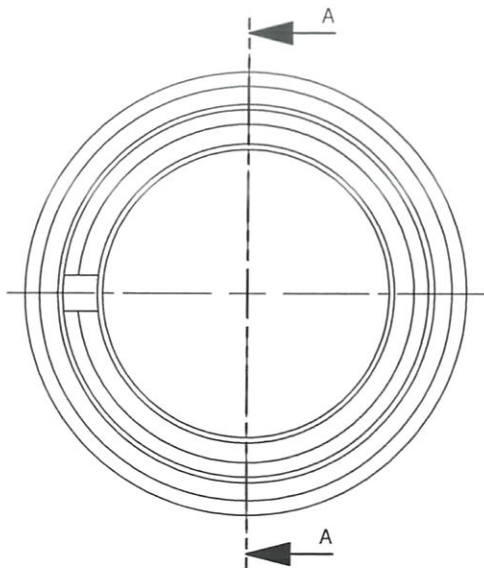

A-A
SCALE 1 : 1

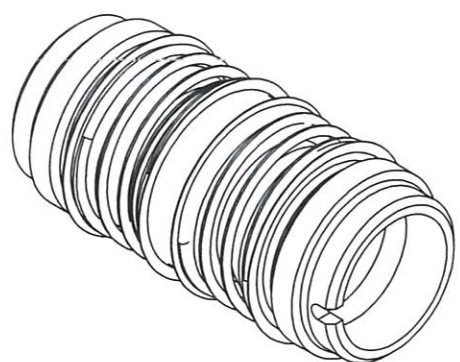

ISOMETRIC VIEW

8	O-RING id x t = 47.29 x 2.62	2	NBR	SEALMART DESIGNATION 111QGAMN
7	MIDDLE DISTANCE RING	1	BRONZE	2012-DWG-BMP-TK-01-100-015-F
6	STATIC HOLDER	2	SS 304	2012-DWG-BMP-TK-01-100-015-E
5	SEALING CONTACT	4	SILICON CARBIDE	2012-DWG-BMP-TK-01-100-015-D
4	MIDDLE RUBBER	2	FKM RUBBER (VITON)	2012-DWG-BMP-TK-01-100-015-C
3	PRESSURE SPRING	2	SPRING STEEL	2012-DWG-BMP-TK-01-100-015-B
2	RUBBER SHELL B	2	SS 304 PLATE	2012-DWG-BMP-TK-01-100-015-A
1	RUBBER SHELL A	2	SS 304 PLATE	2012-DWG-BMP-TK-01-100-015-A
POS	DESCRIPTION	QTY	MATERIAL	REMARKS

FILE DIR: C:\Users\SLCI-D012\Documents\Yessiko\TV 61-100.pump

DIM: mm	NAME	DATE
DRAWN	YESSIKO	9/15/2017
DESIGN	AVAILABLE	<i>Yessiko</i>
CHECK	YESSIKO	
APRV	RULLY	<i>Rully</i>
CANCEL DWG NO.		
REF DWG NO.		

SCALE: 1:2 DIM: mm ASSY NO.

MECHANICAL ENGINEERING SECTION
TITLE TV 61 100 SLURRY PUMP

MECHANICAL SEAL SET SEAL ARRANGEMENT

** INCOMING PART WILL BE CHECK. IT WILL RETURN IF NOT PASS **

POLISHING	GRINDING	NORMAL MACHINING (SMOOTH SURFACE)	NORMAL MACHINING (ROUGH SURFACE)

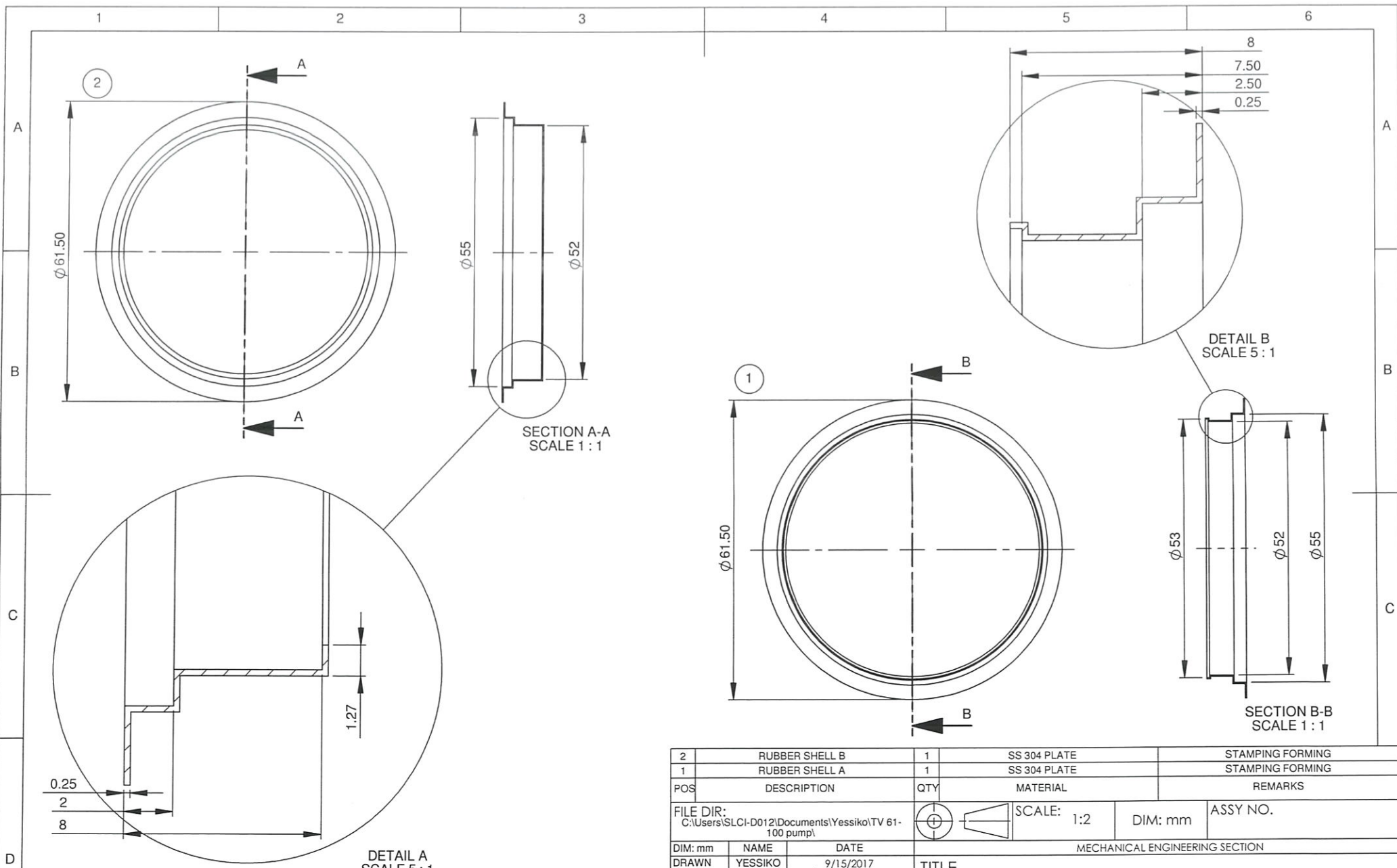

** INCOMING PART WILL BE CHECK. IT WILL RETURN IF NOT PASS **

POLISHING	GRINDING	NORMAL MACHINING (SMOOTH SURFACE)	NORMAL MACHINING (ROUGH SURFACE)

2	RUBBER SHELL B	1	SS 304 PLATE	STAMPING FORMING
1	RUBBER SHELL A	1	SS 304 PLATE	STAMPING FORMING
POS	DESCRIPTION	QTY	MATERIAL	REMARKS
FILE DIR: C:\Users\SLCI-D012\Documents\Yessiko\TV 61-100 pump\			SCALE: 1:2	DIM: mm
DIM: mm		NAME	DATE	ASSY NO.
DRAWN	YESSIKO	9/15/2017	MECHANICAL ENGINEERING SECTION	
DESIGN	AVAILABLE		TITLE RUBBER SHELL	
CHECK	YESSIKO			
APRV	RULLY			
CANCEL DWG NO.				
REF DWG NO.				

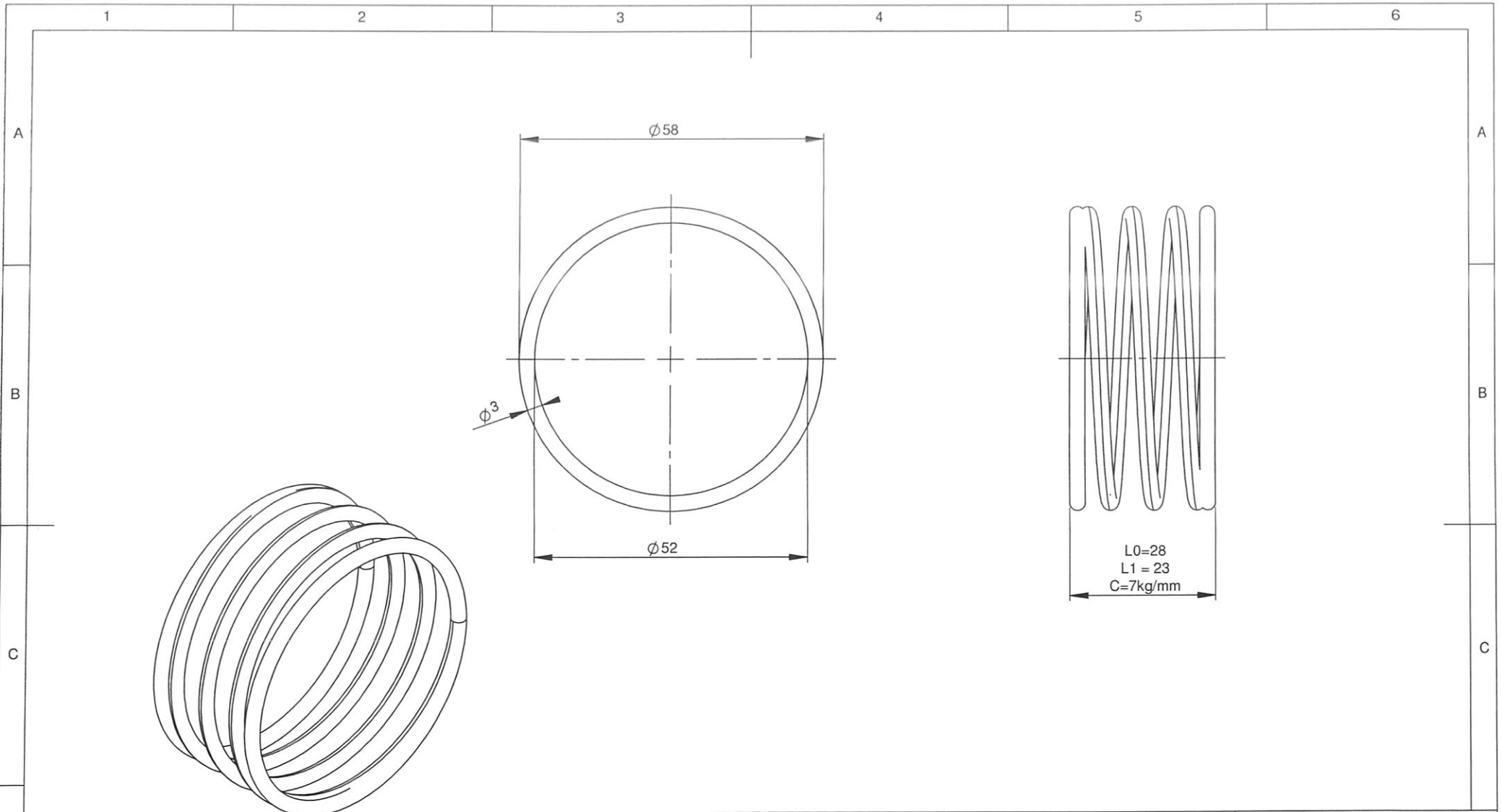

ISOMETRIC VIEW

1	1	1	1	1	1
POS	DESCRIPTION	QTY	MATERIAL	REMARKS	
	PRESSURE SPRING	1	SPRING STEEL	PLEASE CONSIDER WITH SPRING CONST (C)	
FILE DIR: C:\Users\SLCI-D012\Documents\Yessiko\TV 61-100 pump\			SCALE: 1:2	DIM: mm	ASSY NO.
MECHANICAL ENGINEERING SECTION			TITLE		
DIM: mm	NAME	DATE	<p>PRESSURE SPRING</p>		
DRAWN	YESSIKO	9/15/2017			
DESIGN	AVAILABLE	<i>Yessiko</i>			
CHECK	YESSIKO	<i>Yessiko</i>			
APRV	RULLY	<i>Rully</i>			
CANCEL DWG NO.			REF DWG NO.		
PT SCG LIGHTWEIGHT CONCRETE INDONESIA			A4	2012-DWG-BMP-TK-01-100-015-B	REV NO. PAGE
					4

** INCOMING PART WILL BE CHECK. IT WILL RETURN IF NOT PASS **

POLISHING	GRINDING	NORMAL MACHINING (SMOOTH SURFACE)	NORMAL MACHINING (ROUGH SURFACE)

1

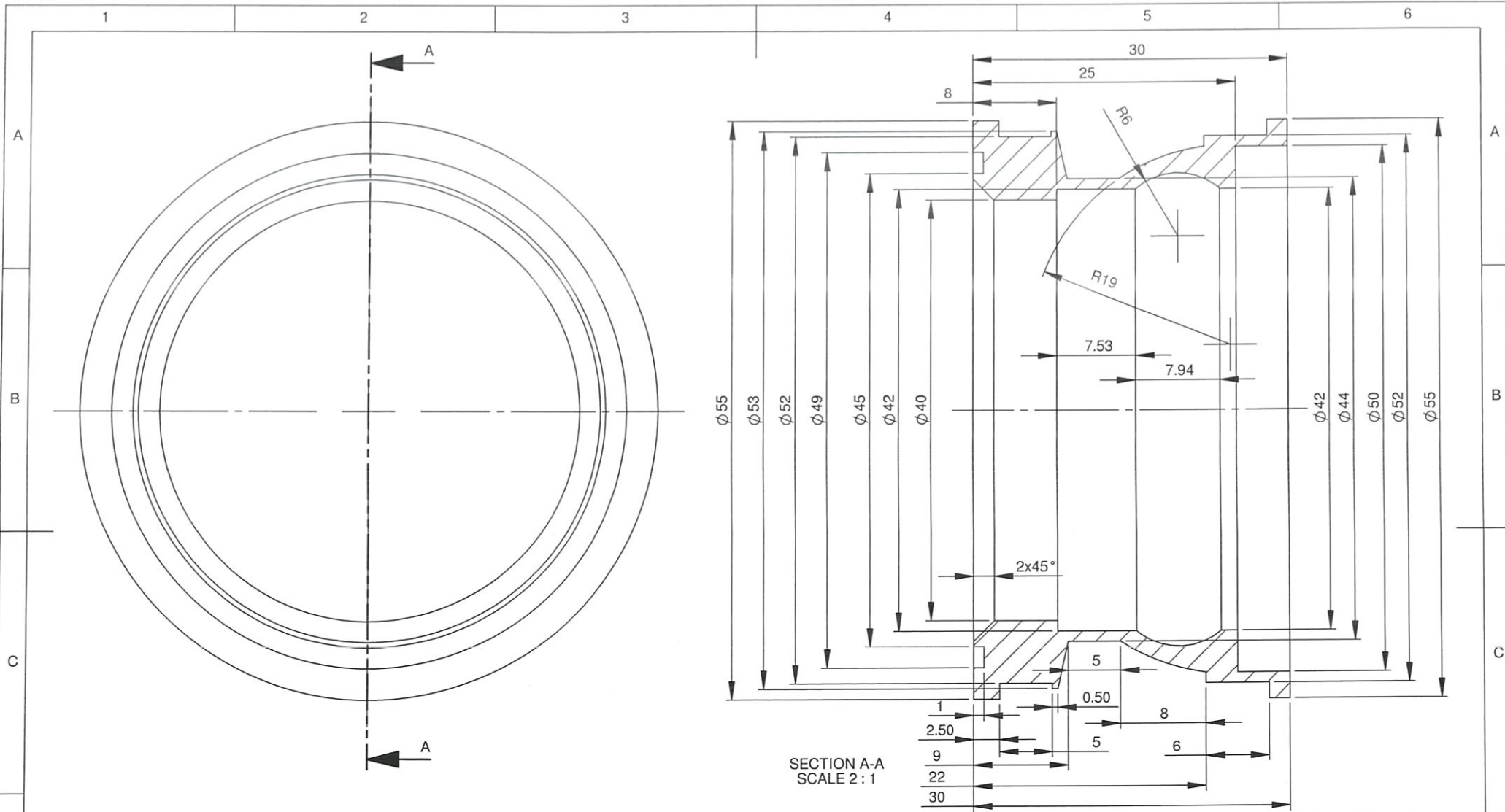

2

3

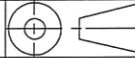

** INCOMING PART WILL BE CHECK. IT WILL RETURN IF NOT PASS **

POLISHING	GRINDING	NORMAL MACHINING (SMOOTH SURFACE)	NORMAL MACHINING (ROUGH SURFACE)
▽▽▽	▽▽	▽	▽

1	MIDDLE RUBBER	2	FKM RUBBER (VITON)	HARDNESS 70-80 SHORE A
POS	DESCRIPTION	QTY	MATERIAL	REMARKS
FILE DIR: C:\Users\SLCI-D012\Documents\Yessiko\TV 61-100 pump\		 SCALE: 1:1		DIM: mm
ASSY NO.		MECHANICAL ENGINEERING SECTION		
DIM: mm	NAME	DATE	TITLE	
DRAWN	YESSIKO	9/15/2017	<h1>MIDDLE RUBBER</h1>	
DESIGN	AVAILABLE			
CHECK	YESSIKO			
APRV	RULLY			
CANCEL DWG NO.				
REF DWG NO.				
 PT SCG LIGHTWEIGHT CONCRETE INDONESIA		A4	2012-DWG-BMP-TK-01-100-015-C	REV NO. PAGE
				5

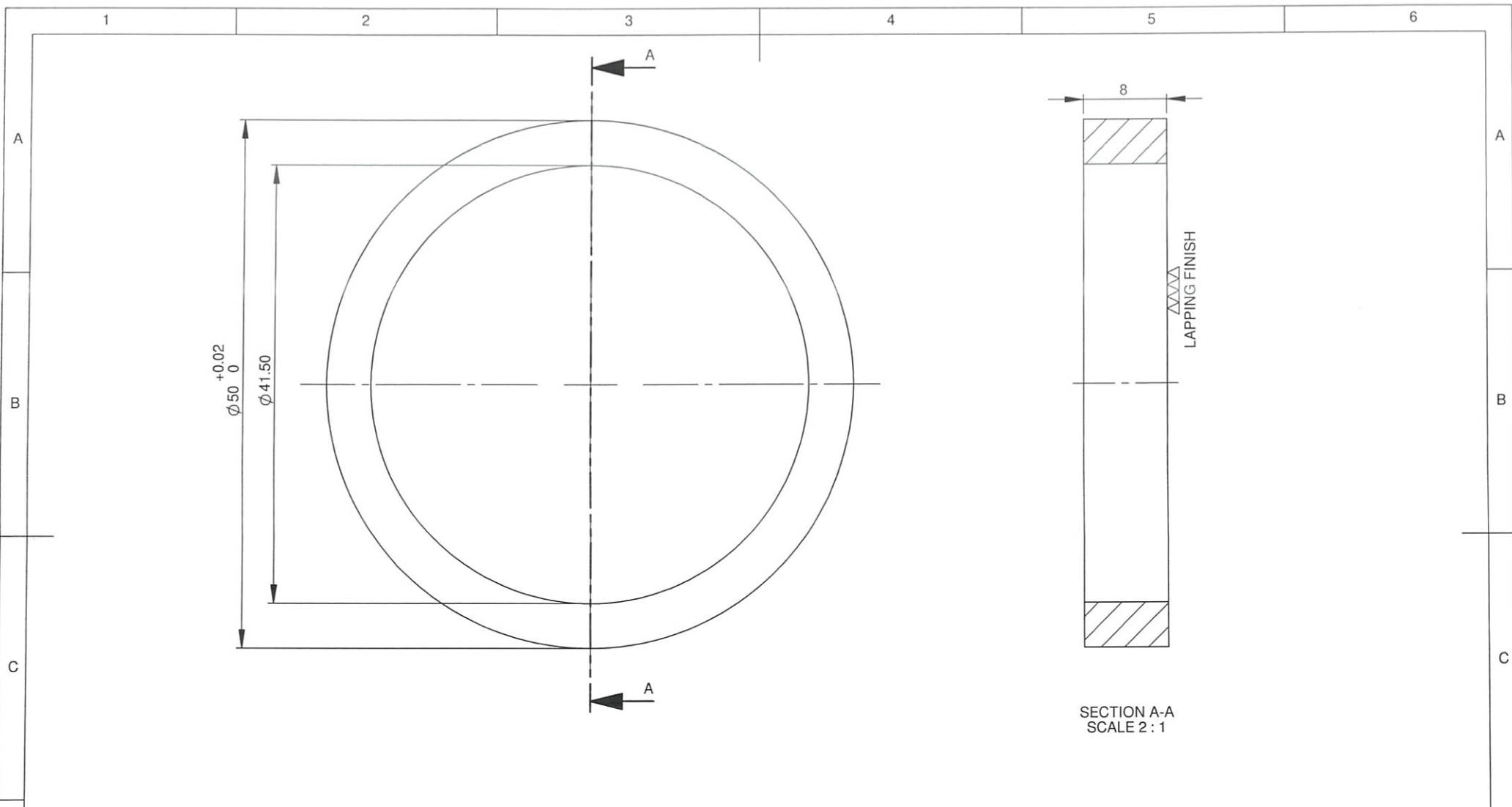

SECTION A-A
SCALE 2 : 1

1	SEALING CONTACT	1	SILICON CARBIDE	LAPPING AND POLISHED SEALING SURFACE
POS	DESCRIPTION	QTY	MATERIAL	REMARKS
FILE DIR: C:\Users\SLCI-D012\Documents\Yessiko\TV 61-100 pump\			SCALE: 1:2	DIM: mm ASSY NO.
DIM: mm		NAME	DATE	MECHANICAL ENGINEERING SECTION
DRAWN	YESSIKO		9/15/2017	TITLE SEALING CONTACT
DESIGN	AVAILABLE			
CHECK	YESSIKO			
APRV	RULLY			
CANCEL DWG NO.				
REF DWG NO.				
		PT SCG LIGHTWEIGHT CONCRETE INDONESIA		A4 2012-DWG-BMP-TK-01-100-015-D
				REV NO. PAGE
				6

** INCOMING PART WILL BE CHECK. IT WILL RETURN IF NOT PASS **

POLISHING	GRINDING	NORMAL MACHINING (SMOOTH SURFACE)	NORMAL MACHINING (ROUGH SURFACE)
1	2	3	

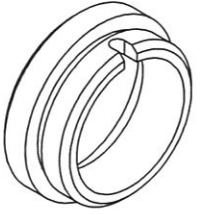
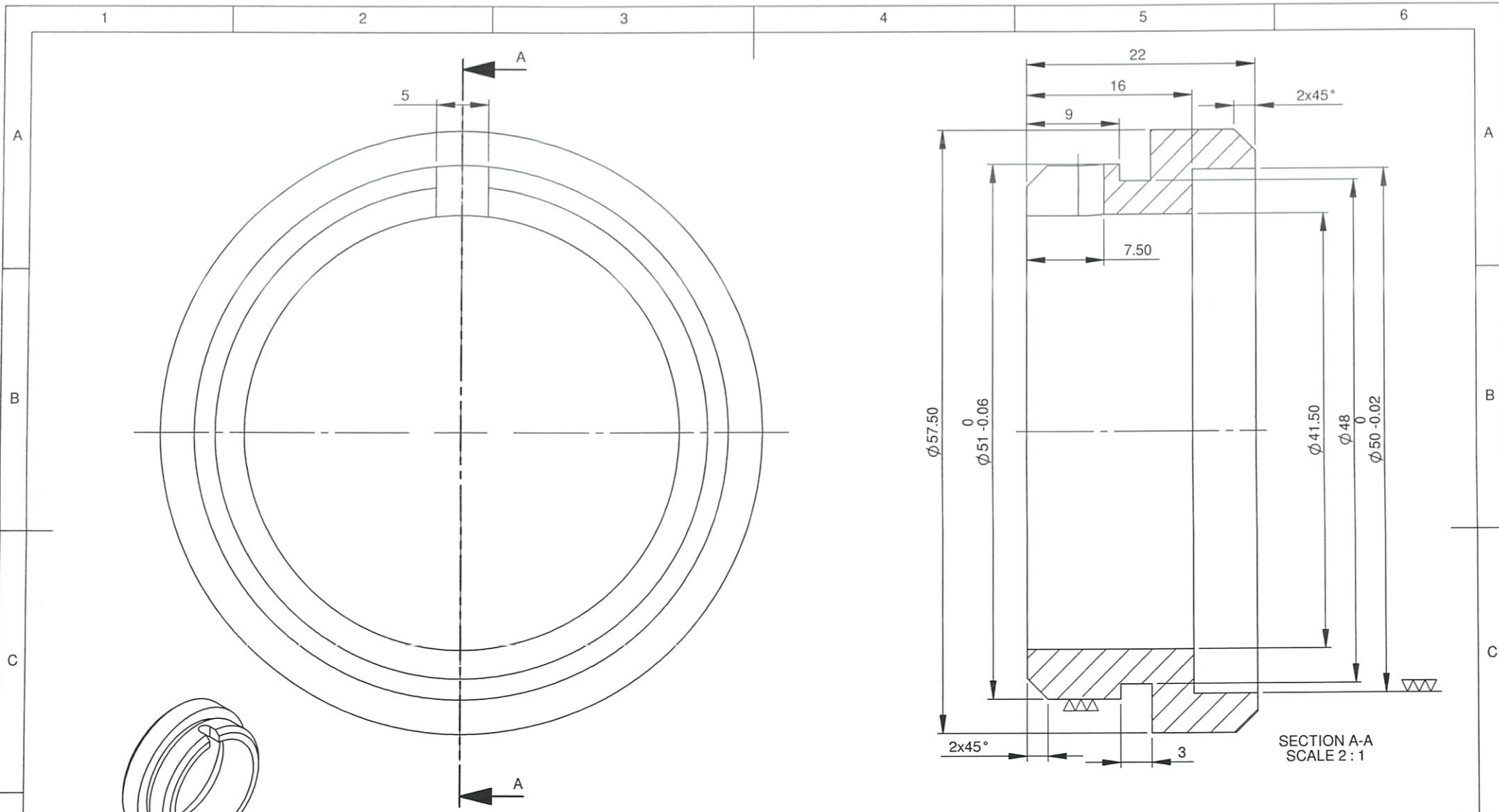

ISOMETRIC VIEW

** INCOMING PART WILL BE CHECK. IT WILL RETURN IF NOT PASS **

POLISHING	GRINDING	NORMAL MACHINING (SMOOTH SURFACE)	NORMAL MACHINING (ROUGH SURFACE)
▽▽▽	▽▽	▽	▽

1	STATIC HOLDER	1	SS 304	
POS	DESCRIPTION	QTY	MATERIAL	REMARKS
FILE DIR: C:\Users\SLCI-D012\Documents\Yessiko\TV 61-100 pump\			SCALE: 1:1	ASSY NO.
			DIM: mm	
MECHANICAL ENGINEERING SECTION				
DIM: mm	NAME	DATE	TITLE	
DRAWN	YESSIKO	9/15/2017	<h1>STATIC HOLDER</h1>	
DESIGN	AVAILABLE			
CHECK	YESSIKO	<i>Yessiko</i>		
APRV	RULLY	<i>Rully</i>		
CANCEL DWG NO.				
REF DWG NO.				
PT SCG LIGHTWEIGHT CONCRETE INDONESIA			A4	2012-DWG-BMP-TK-01-100-015-E
			REV NO.	PAGE
				7

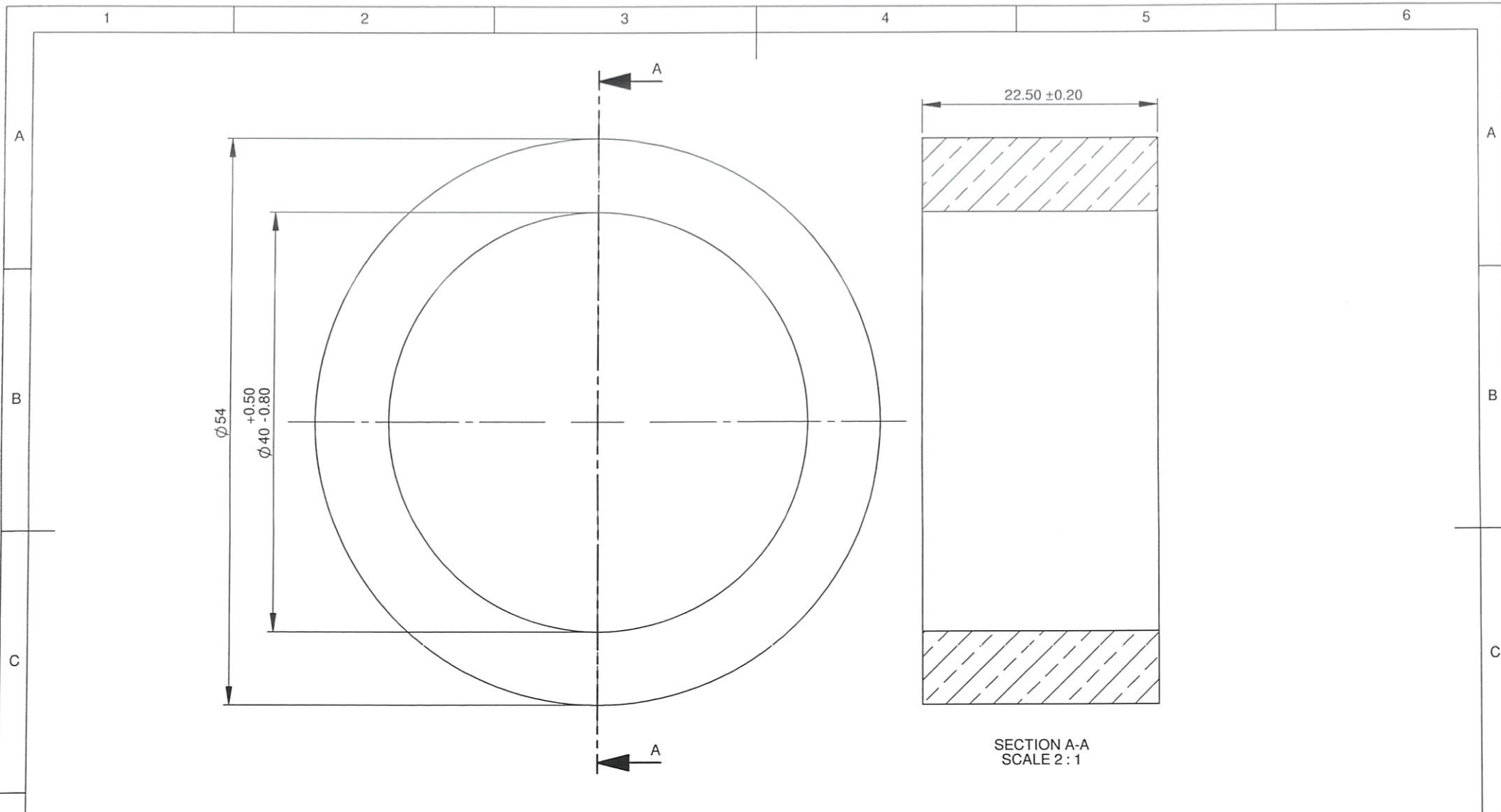

SECTION A-A
SCALE 2 : 1

1	MIDDLE DISTANCE RING	1	BRONZE	
POS	DESCRIPTION	QTY	MATERIAL	REMARKS
FILE DIR: C:\Users\SLCI-D012\Documents\Yessiko\TV 61-100 pump\			SCALE: 1:1	DIM: mm
			ASSY NO.	
DIM: mm	NAME	DATE	MECHANICAL ENGINEERING SECTION	
DRAWN	YESSIKO	9/15/2017	TITLE MIDDLE DISTANCE RING	
DESIGN	AVAILABLE			
CHECK	YESSIKO			
APRV	RULLY			
CANCEL DWG NO.				
REF DWG NO.				
PT SCG LIGHTWEIGHT CONCRETE INDONESIA		A4	2012-DWG-BMP-TK-01-100-015-F	REV NO. PAGE
			8	

** INCOMING PART WILL BE CHECK. IT WILL RETURN IF NOT PASS **

POLISHING	GRINDING	NORMAL MACHINING (SMOOTH SURFACE)	NORMAL MACHINING (ROUGH SURFACE)
▽▽▽	▽▽	▽	▽
1	2	3	