

# Display Purchase Req. 1021013079

Document Overview On Personal Setting

2010 PR frm MRP/CBP

Header

Requisn Date	Status	Item	A	I	Material	Short Text	Quantity	Unit	Delivery Date	Per	Requisnr.	Material Group	Plant	Stor. Loc.	PGr	Total Value
10.02.2023		10	K			Assy Coupling Vibrator Motor ...	3	PC	28.02.2023	1	Taufik	Supplies	PT SLCI		DBA	2,400,000
10.02.2023		20	K			Assy Coupling Vibrator Motor ...	3	PC	28.02.2023	1	Taufik	Supplies	PT SLCI		DBA	1,800,000

Item

Item Texts	A...	
•  Item text	<input checked="" type="checkbox"/>	Purpose: Assy Coupling for Motor Vibrator [see DWG] GL: 52307 CC: 2011-10000
•  Item note	<input type="checkbox"/>	
•  Delivery text	<input type="checkbox"/>	
•  Material PO text	<input type="checkbox"/>	

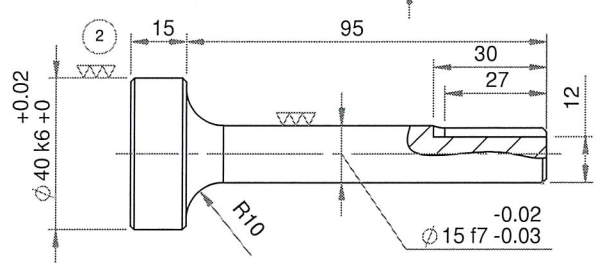
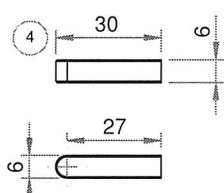
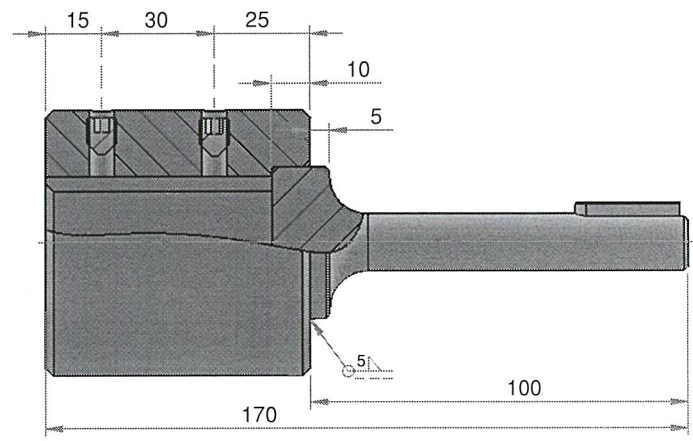
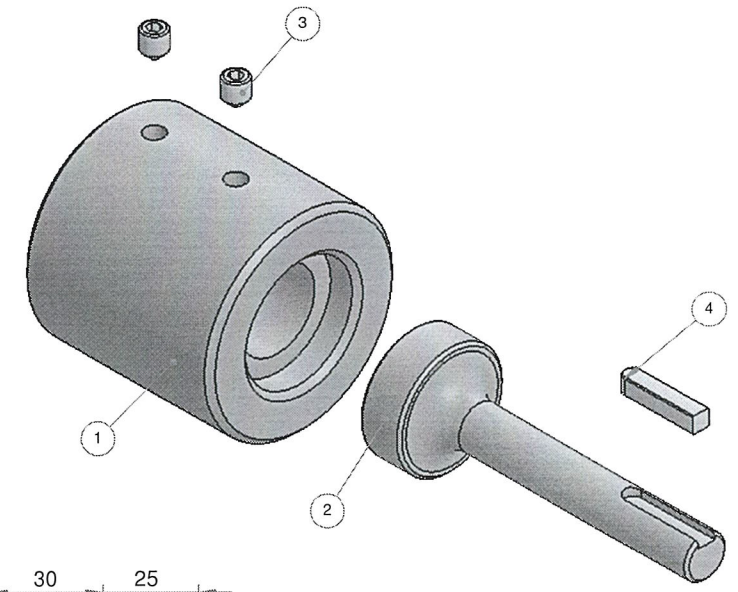
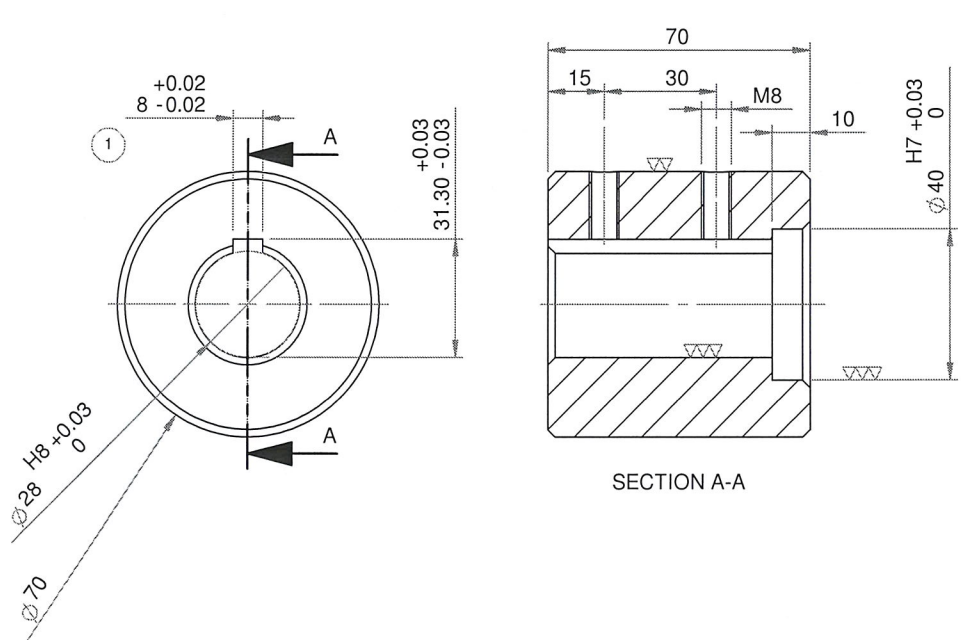

POS	DESCRIPTION	QTY	MATERIAL	REMARKS
4	KEY SHAFT	1	SS-400	-
3	HEX SOCKET CONE M8x1.25x10	2	HTBN 8.8	-
2	FRONT COUPLING	1	S45C	-
1	BACK COUPLING $\phi 24$ mm	1	S45C	-

FILE DIR: \\192.168.4.15\mechanical\Draft Nuryana\Proyek Pak Kamal\Tulale mixing vibrator\Modified\2014\

SCALE: 1:2 DIM: mm ASSY NO.

Mechanical Engineering Section

TITLE MIXING PLAN - VIBRATOR

**ASSY COUPLING MOTOR VIBRATOR  $\phi 28$  mm**

CHECK YESSIKO  
APRV M.NUGRAHA

CANCEL DWG NO.  
REF DWG NO.

\*\* INCOMING PART WILL BE CHECK. IT WILL RETURN IF NOT PASS \*\*

POLISHING	GRINDING	NORMAL MACHINING (SMOOTH SURFACE)	NORMAL MACHINING (ROUGH SURFACE)
1	1	2	3

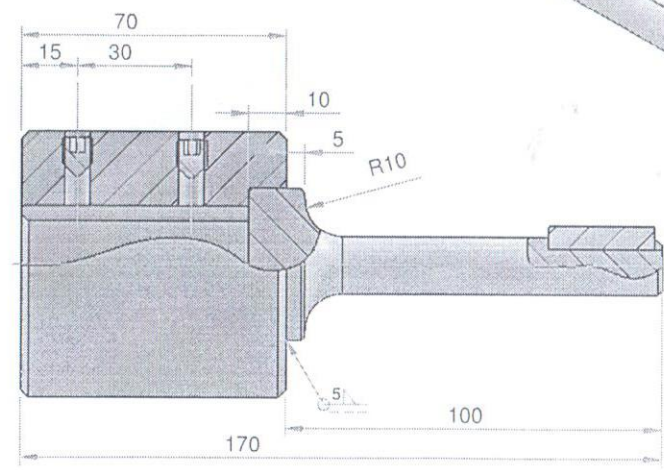
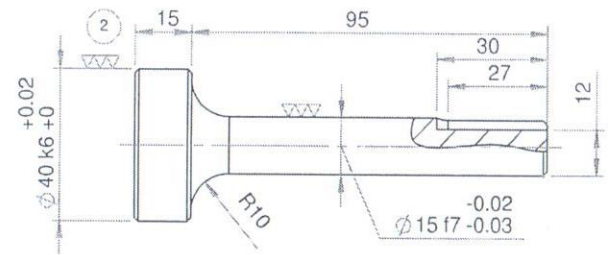
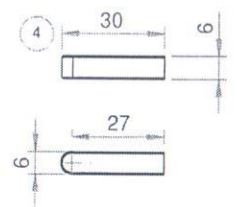
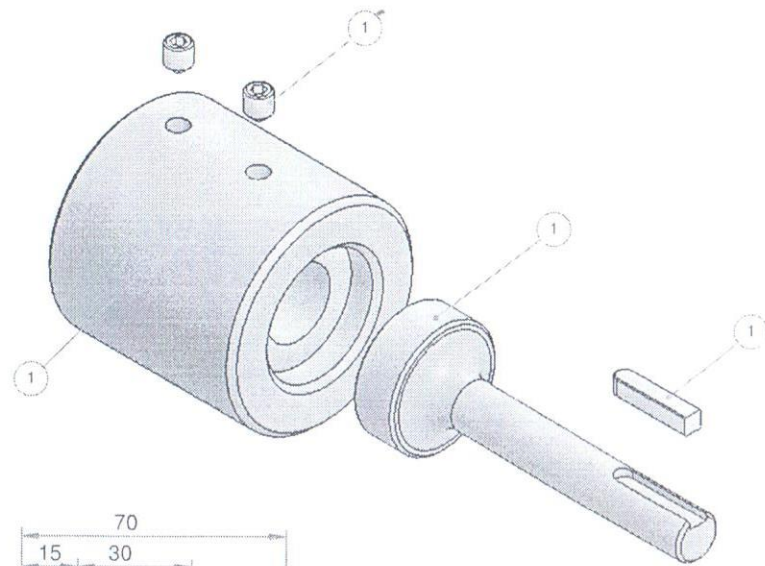
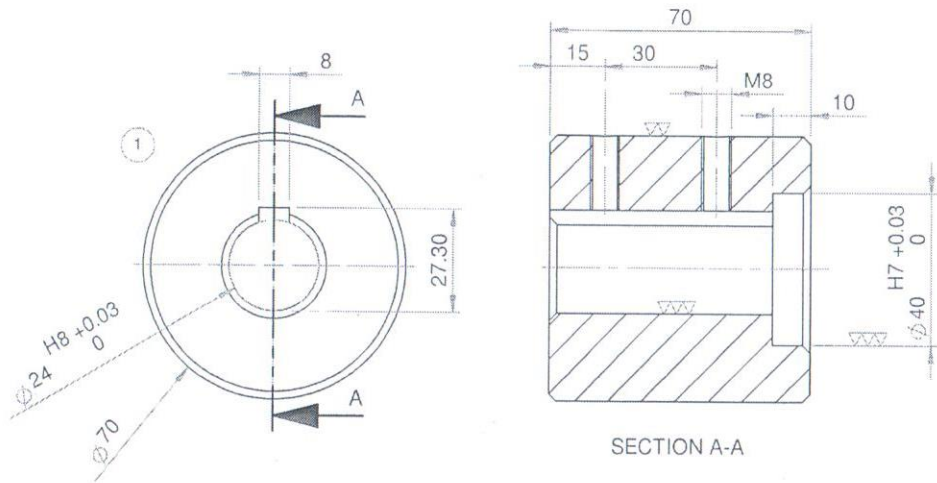

4	KEY SHAFT	1	SS-400	-
3	HEX SOCKET CONE M8x1.25x10	2	HTBN 8.8	-
2	FRONT COUPLING	1	S45C	-
1	BACK COUPLING $\phi 28$ mm	1	S45C	-
POS	DESCRIPTION	QTY	MATERIAL	REMARKS
FILE DIR: \\192.168.4.15\mechanical\Draft\Nuryana\Proyek Pak Kamal\Tulale mixing vibrator\Modified\2014\			SCALE: 1:2	ASSY NO.
DIM: mm			MECHANICAL ENGINEERING SECTION	
DRAWN	NAME	DATE	TITLE MIXING PLAN - VIBRATOR	
DESIGN	AVAILABLE	7/24/2018	<h1>ASSY COUPLING MOTOR VIBRATOR <math>\phi 24</math> mm</h1>	
CHECK	YESSIKO			
APRV	M.NUGRAHA			
CANCEL DWG NO.				
REF DWG NO.				

\*\* INCOMING PART WILL BE CHECK. IT WILL RETURN IF NOT PASS \*\*

POLISHING GRINDING NORMAL MACHINING (SMOOTH SURFACE) NORMAL MACHINING (ROUGH SURFACE)