

Display Purchase Req. 1021013719

Document Overview On Personal Setting

2010 PR frm MRP/CBP

Header

Default Values

Requisn Date	Status	Item	A	I	Material	Short Text	Quantity	Unit	Delivery Date	Per	Requisnr.	Material Group	Plant	Stor. Loc.	PGr	Total Value
31.07.2023		10	K			Making Bucket (Bucket Elevat...	10	PC	31.08.2023	1	Robby	Supplies	PT SLCI		DBA	7,500,000

Item

- Item Texts
- Item text
 - Item note
 - Delivery text
 - Material PO text

Purpose:

Making new Bucket, Bucket Elevator Sand Machine

GL: 523072
CC: 2011-10000

Continuous-tex...

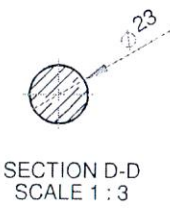
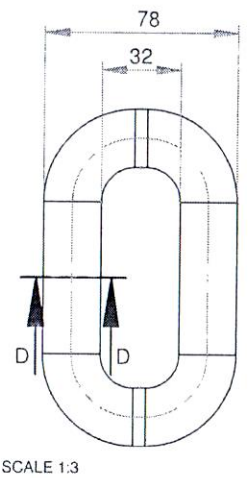
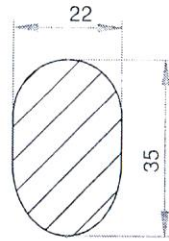
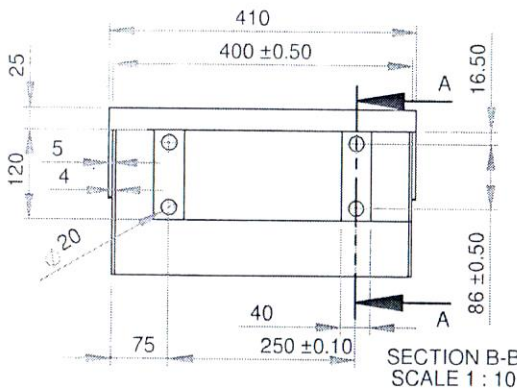
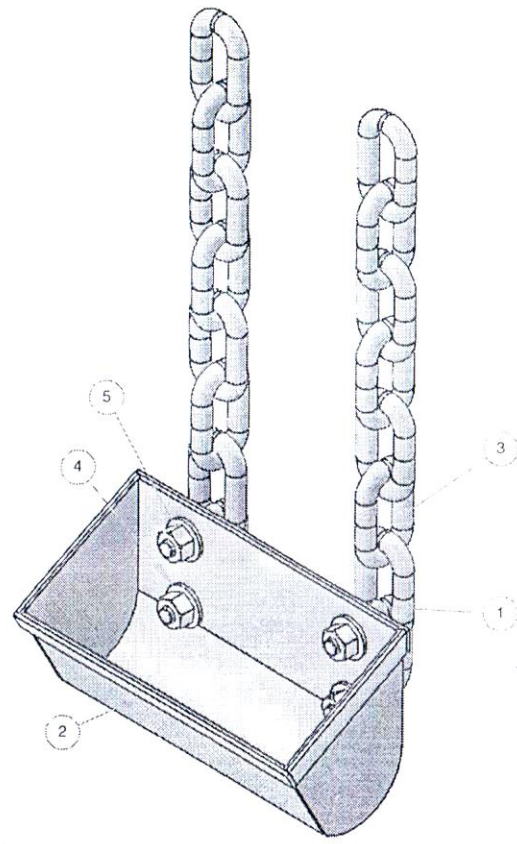
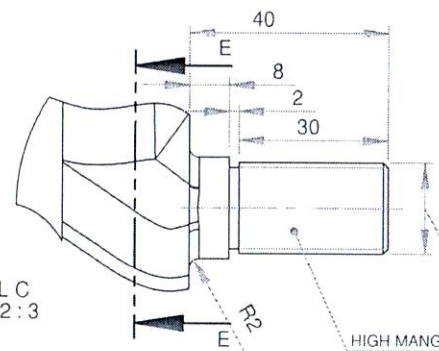
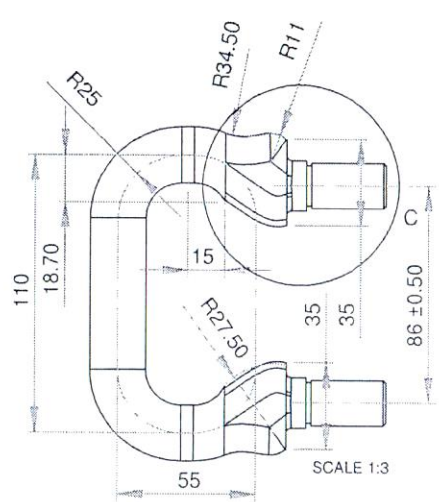
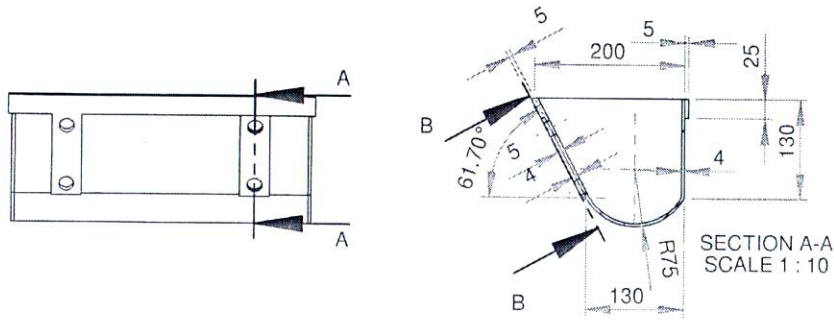

5	NUT M18x2.5	2	HTBN 8.8	
4	WASHER PLATE M18	2	SPRING STEEL	
3	CHAIN EYE	14	HIGH MANGANESE STEEL (FORGING)	CASTING PROCESS WILL BE ACCEPTABLE
2	BUCKET	1	ANTI WEAR PLATE	HARDOX 500 OR COMPATIBLE
1	LOCKING CHAIN	2	HIGH MANGANESE STEEL (FORGING)	CASTING PROCESS WILL BE ACCEPTABLE
POS	DESCRIPTION	QTY	MATERIAL	REMARKS

FILE DIR: \\192.168.4.15\mechanical\Draft\Nuryana\Proyek Pak Yessiko\Bucket elevator\ SCALE: 1:20 DIM: mm ASSY NO. _____

DRAWN ENDEN 03-Sep-18			MECHANICAL ENGINEERING SECTION	
DESIGN	AVAILABLE	TITLE BUCKET ELEVATOR 01		
CHECK	YESSIKO	<h1>ASSEMBLY SEVEN</h1> <h2>CHAIN LINK (EXISTING)</h2>		
APRV	M. MUGRAHA			
CANCEL DWG NO.				
REF DWG NO.				

** INCOMING PART WILL BE CHECK. IT WILL RETURN IF NOT PASS **

POLISHING	GRINDING	NORMAL MACHINING (SMOOTH SURFACE)	NORMAL MACHINING (ROUGH SURFACE)