

Display Purchase Req. 1021014517

Document Overview On Personal Setting

2010 PR frm MRP/CBP ▾ 1021014517

Header

Default Values

Requisn Date	Status	Item	A	I	Material	Short Text	Quantity	Unit	Delivery Date	Per	Requisnr.	Material Group	Plant	Stor. Loc.	PGr	Total Value
03.01.2024		10	K			Making New Screen for Buck..	1	LOT	31.01.2024	1	Robby	Supplies	PT SLCI		DBA	4,850,000

Item [10] Making New Screen for Bucket Palm Ker... ▲ ▼

Material Data | Quantities/Dates | Valuation | Account Assignment | Source of Supply | Status | Contact Person | Texts | Delivery Address | Spec2000 / SC

Item Texts	A...	
• Item text	✓	Purpose: Screen for Palm Kernel Bucket (Boiler) GL: 521101 CC: 2011-11900
• Item note		
• Delivery text		
• Material PO text		

◀ ▶ Continuous-tex... ▾

A

B

C

D

A

B

C

D

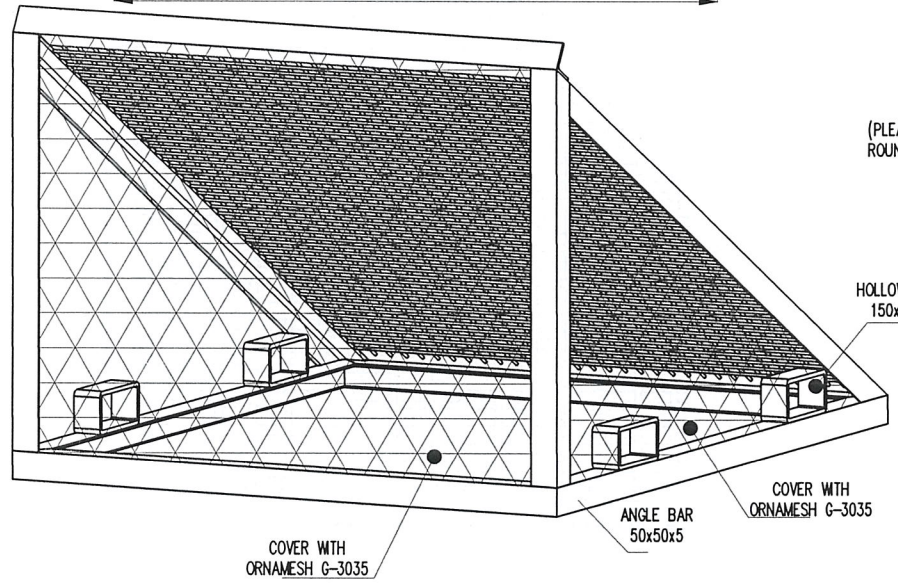
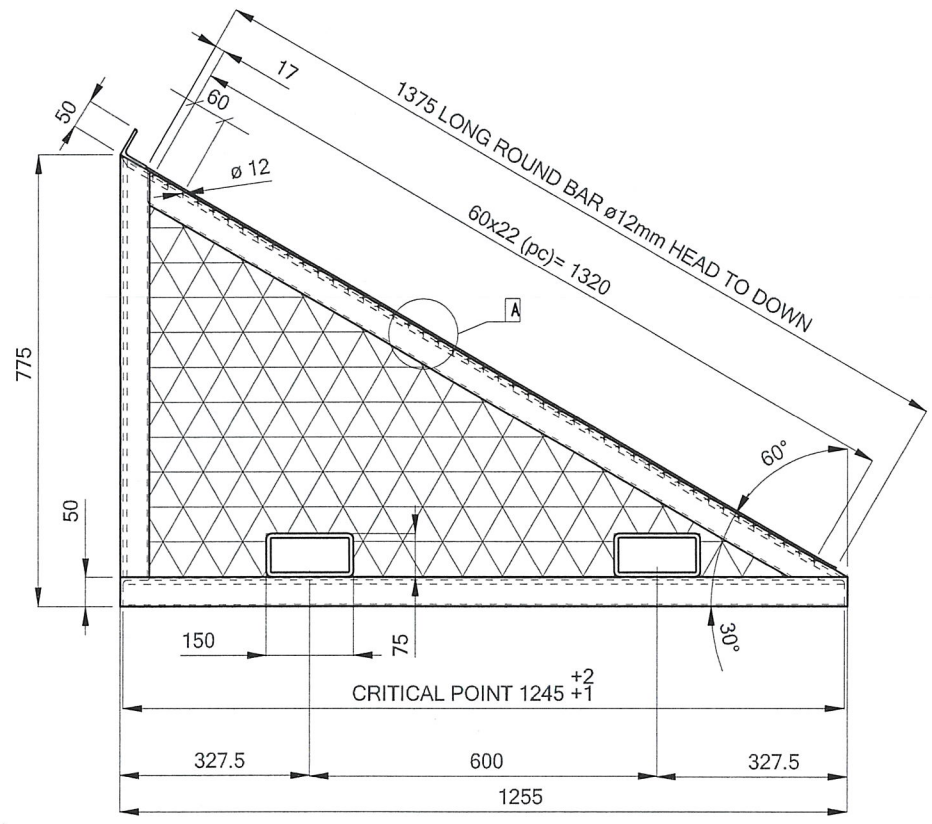
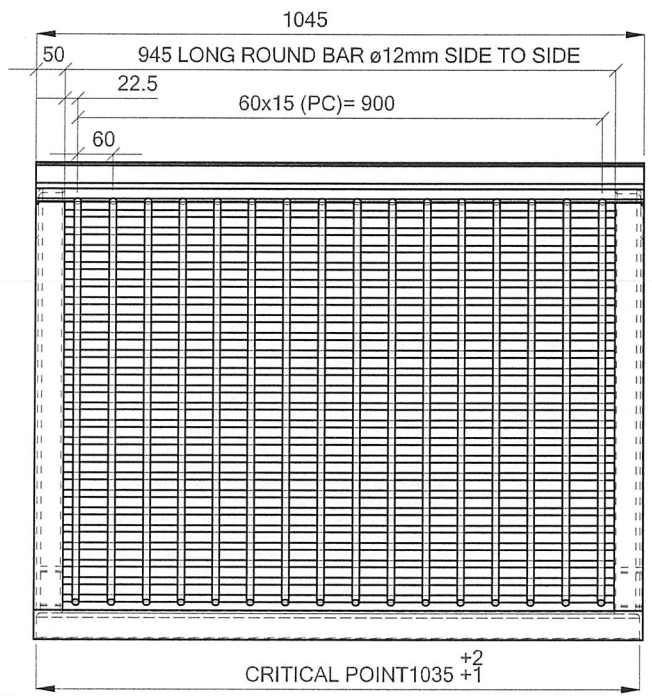

(PLEASE UNDER POSITION)
ROUND BAR LONG 945mm

(PLEASE TOP POSITION)
ROUND BAR LONG 1375mm

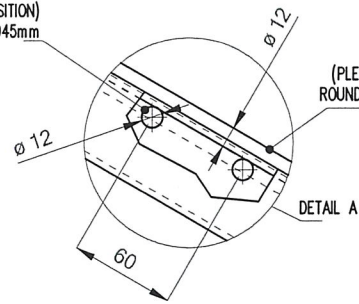

** INCOMING PART WILL BE CHECK. IT WILL RETURN IF NOT PASS **

POLISHING	GRINDING	NORMAL MACHINING (SMOOTH SURFACE)	NORMAL MACHINING (ROUGH SURFACE)
▽▽▽	▽▽	▽	▽

1	FILTER	1	SS-400	-
POS	DESCRIPTION	QTY	MATERIAL	REMARKS
FILE DIR:	-	SCALE:	1:13	DIM: mm
				ASSY NO.
MECHANICAL ENGINEERING SECTION				
TITLE BOILER AND AUTOCLAVE - BUCKET				
TOP BUCKET+SCREEN				
REF DWG NO.				