

Display Purchase Req. 1021014549

Document Overview On | Personal Setting

2010 PR frm MRP/CBP | 1021014549

Header

Default Values

Requisn Date	Status	Item	A	I	Material	Short Text	Quantity	Unit	Delivery Date	Per	Requisnr.	Material Group	Plant	Stor. Loc.	PGr	Total Value
04.01.2024		10	K			Long Elbow Pipe A [see DWG]	1	PC	31.01.2024	1	Robby	Supplies	PT SLCI		DBA	3,200,000
04.01.2024		20	K			Long Elbow Pipe B [see DWG]	1	PC	31.01.2024	1	Robby	Supplies	PT SLCI		DBA	3,200,000

Item [10] Long Elbow Pipe A [see DWG]



- Material Data
- Quantities/Dates
- Valuation
- Account Assignment
- Source of Supply
- Status
- Contact Person
- Texts
- Delivery Address
- Spec2000 / SC

Item Texts	A...	
• Item text	<input checked="" type="checkbox"/>	Purpose: Replacement Long Elbow for Slurry Transport from Slush Pump to Gutter Line GL: 523072 CC: 2011-11900
• Item note	<input type="checkbox"/>	
• Delivery text	<input type="checkbox"/>	
• Material PO text	<input type="checkbox"/>	

◀ ▶ Continuous-tex...

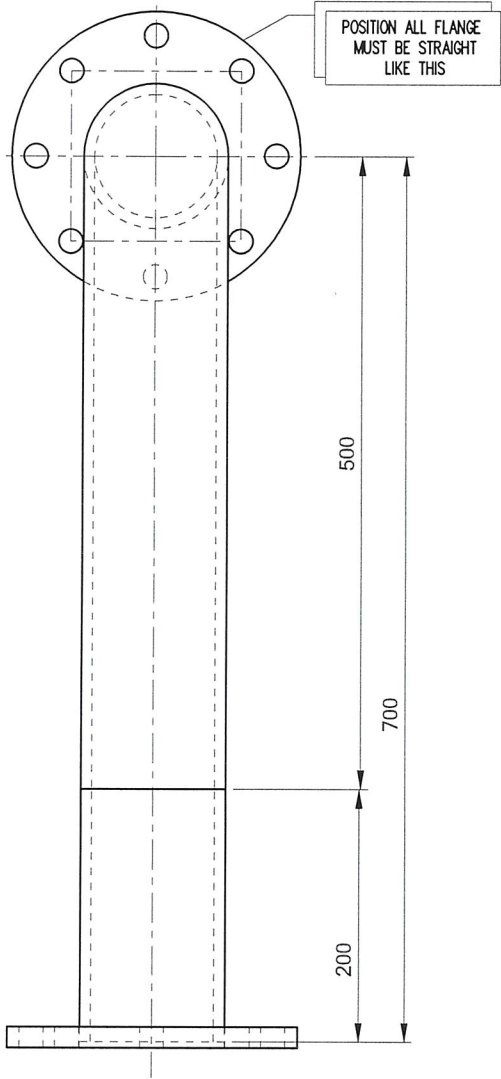

*NB= ESTIMATION WEIGHT: 34 KG

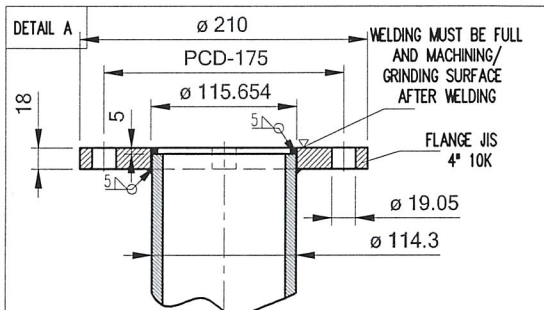
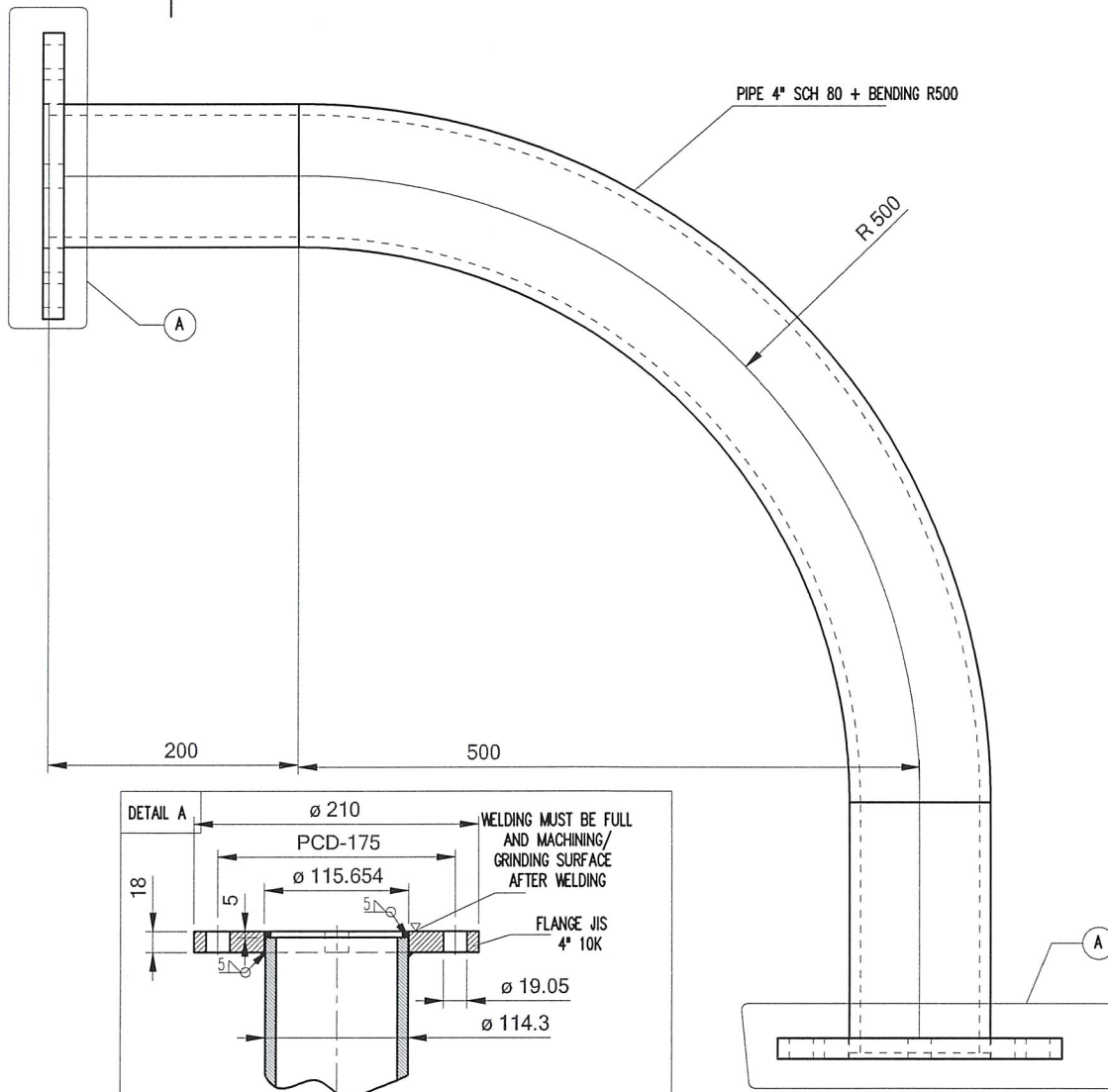

** INCOMING PART WILL BE CHECK. IT WILL RETURN IF NOT PASS **

POLISHING	GRINDING	NORMAL MACHINING (SMOOTH SURFACE)	NORMAL MACHINING (ROUGH SURFACE)
▽▽▽	▽▽	▽	▽

1	LONG ELBOW 1	1	PIPE 4" SCH 80 + FLANGE 4" JIS 10K	-
POS	DESCRIPTION	QTY	MATERIAL	REMARKS
FILE DIR: _		SCALE: 1:6		ASSY NO.
DIM: mm		MECHANICAL ENGINEERING SECTION		
DRAWN	ENDEN	DATE	14/JAN/20	
DESIGN	B. ARIFIN	DATE	14/JAN/20	
CHECK	YESSIKO	DATE		
APRV	MNUGRAHA	DATE		
TITLE MIXING PLAN - WASTE CUTTING (MST 6/4 SLUSH PUMP)				
LONG ELBOW 1				
(*) = GENERAL TOLERANSI ±0.2% x DIMENSION				
REF DWG NO.				



PT SCG LIGHTWEIGHT CONCRETE INDONESIA

A4

2012-DWG-MPL-WC-M-002-N-3

REV NO. PAGE
- -

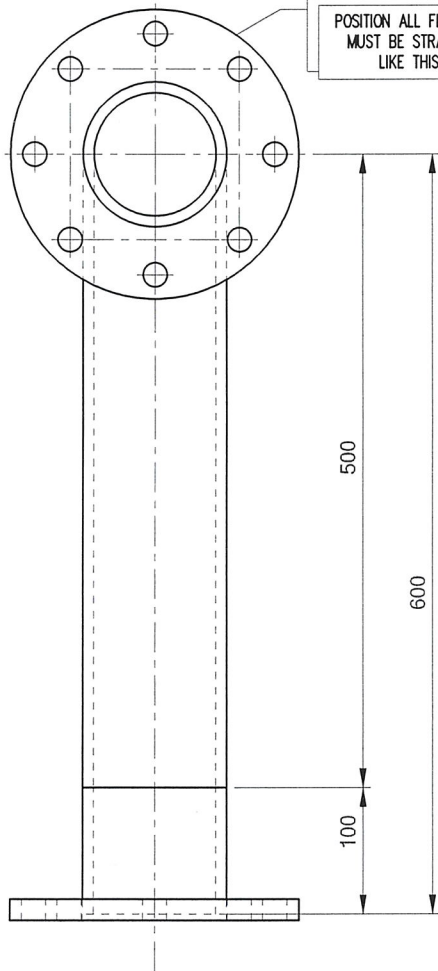

*NB= ESTIMATION WEIGHT: 32 KG

** INCOMING PART WILL BE CHECK. IT WILL RETURN IF NOT PASS **

POLISHING	GRINDING	NORMAL MACHINING (SMOOTH SURFACE)	NORMAL MACHINING (ROUGH SURFACE)
▽▽▽▽	▽▽▽	▽▽	▽

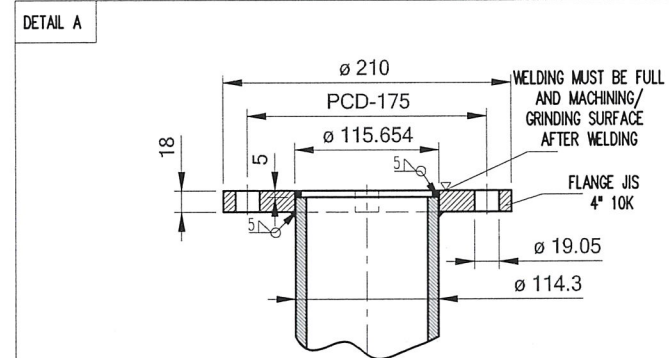
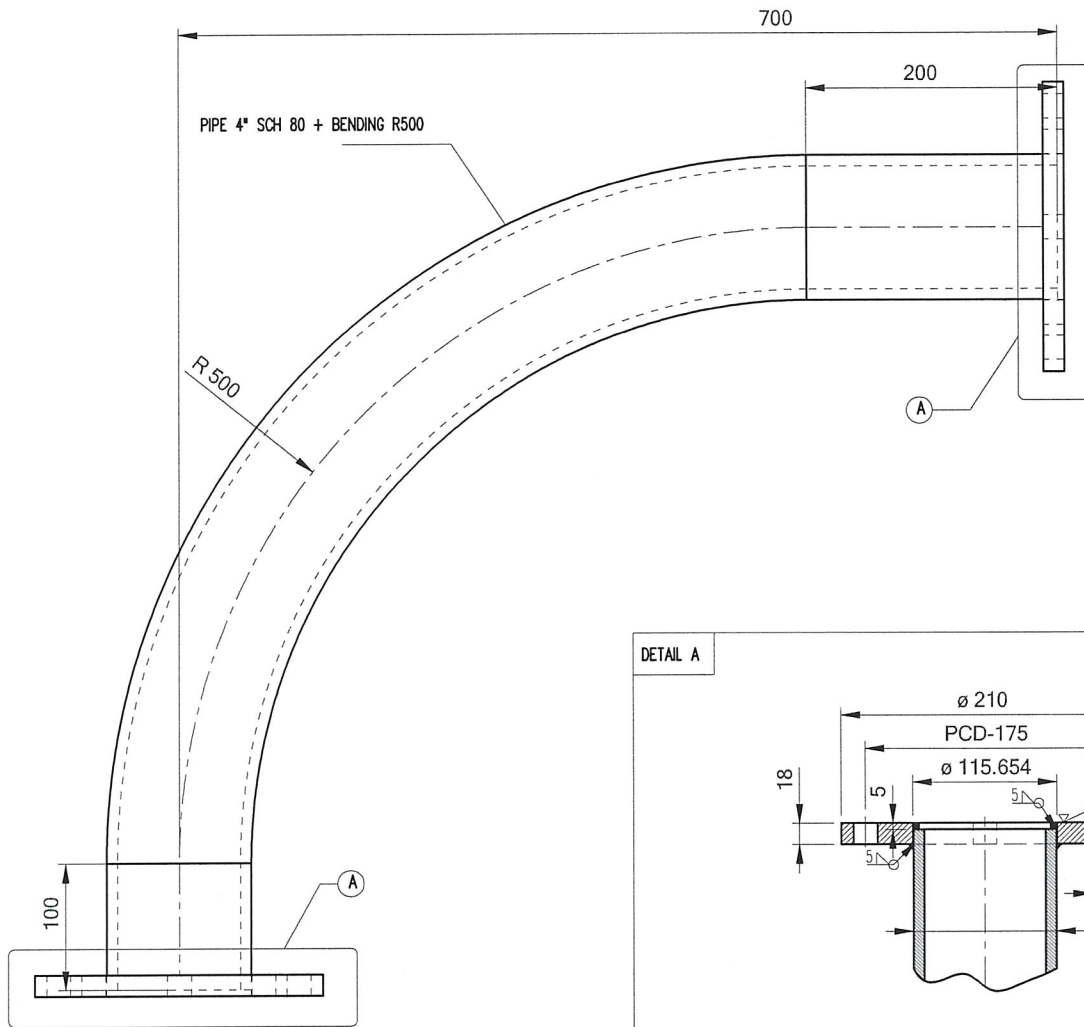

1	LONG ELBOW 2	1	PIPE 4" SCH 80 + FLANGE 4" JIS 10K	-
POS	DESCRIPTION	QTY	MATERIAL	REMARKS
FILE DIR:			SCALE: 1:6	DIM: mm ASSY NO.
MECHANICAL ENGINEERING SECTION				
TITLE MIXING PLAN - WASTE CUTTING (MST 6/4 SLUSH PUMP)				
LONG ELBOW 2				
REF DWG NO.				



PT SCG LIGHTWEIGHT CONCRETE INDONESIA

A4

2012-DWG-MPL-WC-M-002-N-5

REV NO. PAGE
- -