

Display Purchase Req. 1021014978

Document Overview On Personal Setting

2010 PR frm MRP/CBP

Header

Default Values

Requisn Date	St...	Item	A	I	M	Short Text	Quantity	Unit	Delivery Date	P...	Requisitioner	Matl Group	Plant	Stor. Loc.	Purch. Grp	Total Value
22.04.2024		10	K			Cam Cross Cutter Type A	4	PC	09.05.2024	1	Robby	Supplies	PT SLCI		DBA	2,600,000
22.04.2024		20	K			Cam Cross Cutter Type B	4	PC	09.05.2024	1	Robby	Supplies	PT SLCI		DBA	2,600,000

Item



- Material Data
- Quantities/Dates
- Valuation
- Account Assignment
- Source of Supply
- Status
- Contact Person
- Texts
- Delivery Address
- Spec2000 / SC

Item Texts	A...	
Item text	<input checked="" type="checkbox"/>	Purpose: Cross Cutter (Prevent Reject & Improve Quality) GL: 523072 CC: 2011-11900
Item note	<input type="checkbox"/>	
Delivery text	<input type="checkbox"/>	
Material PO text	<input type="checkbox"/>	

Continuous-tex...

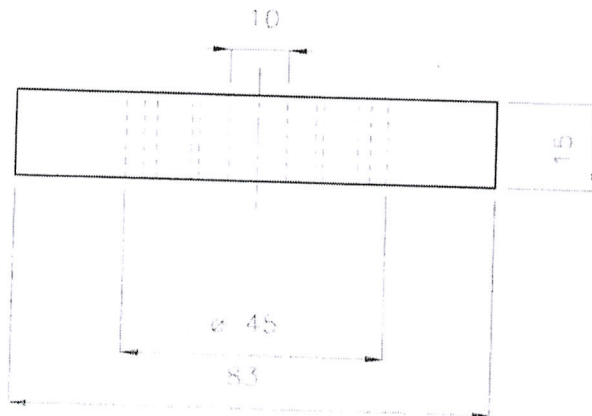
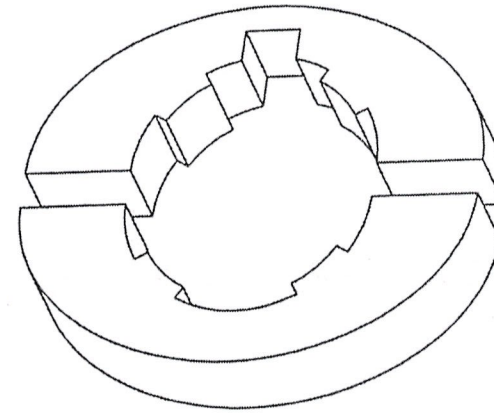
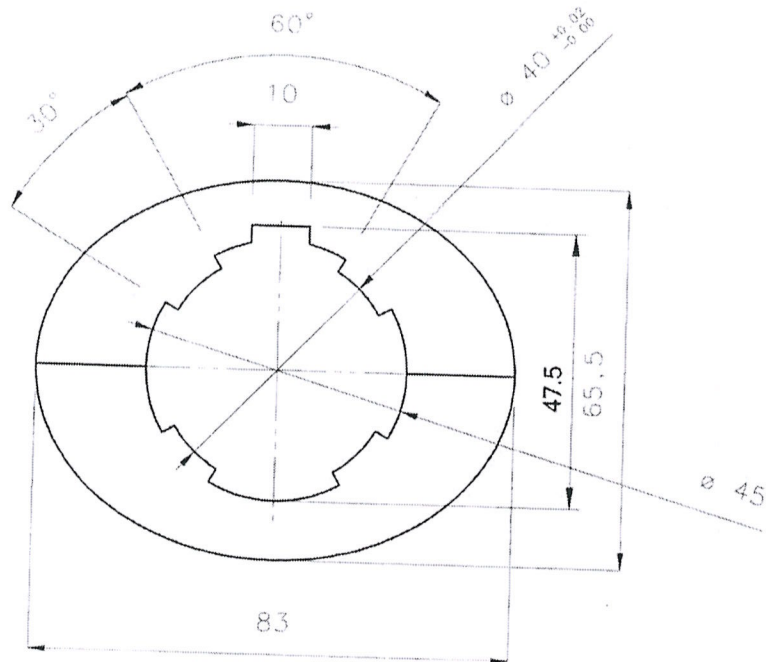

*Material VCN 150
*Hardening 50 HRC

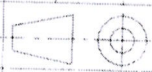
1	Cam cross Cutter	1	VCN 150	
No	Description	Qty	Material	Remarks
	DIR/File:C:\Spiderman\Desktop\SLC\Project varicad\ cam cross cutter		Scale	Assy No.
DIM : mm	Name	Date	 <p>Cross Cutter Cam Cross Cutter TYPE A</p>	
Drawn	Sigit	26 august'15		
Designed				
Checked	Bp.Rully	20-10-16		
Approved	Bp.Nugi			
DIM : mm				
PT.SCG Lightweight concrete Indonesia A4		2012-DWG-WKB-CC B-001		Page 01

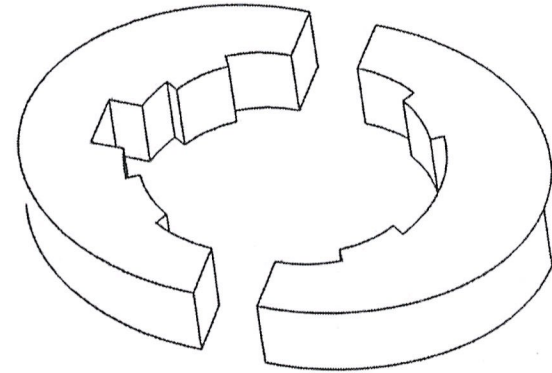
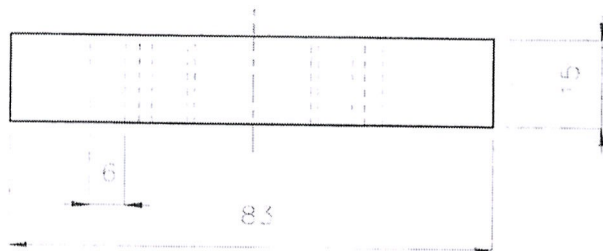
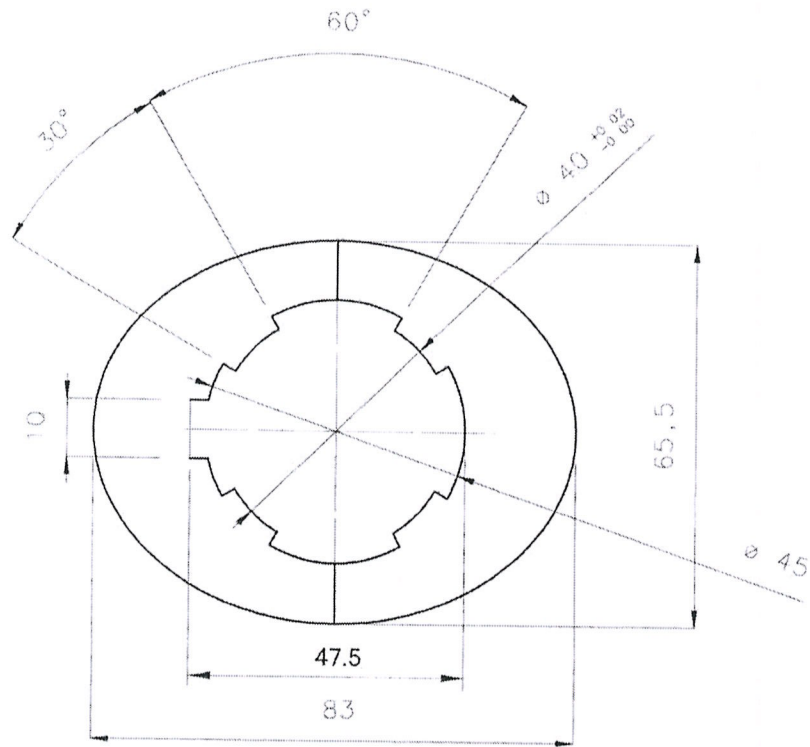

Isometric view

*Material VCN 150
 *Hardening 50 HRC

1	Cam cross Cutter	1	VCN 150	
No	Description	Qty	Material	Remarks
	DIR:/File:C:\Spiderman\Desktop\SLC\I\Project varicad\ cam cross cutter		Scale	Assy No.
DIM : mm	Name	Date	 Cross Cutter Cam Cross Cutter TYPE B	
Drawn	Sigit	26 augst'15		
Designed				
Checked	Bp.Rully	20-10-16		
Approved	Bp.Nugi			
DIM : mm				
PT.SCG Lightweight concrete Indonesia		A4	2012-DWG-WKB-CC B-002	Page 02